



FORT COLLINS-LOVELAND WATER DISTRICT  

---

STANDARD CONSTRUCTION SPECIFICATIONS

June 2010

Revision 2.0

## TABLE OF CONTENTS

### SUMMARY OF WORK

#### GENERAL

1.1	Scope	01010-1
1.2	Specifications Documents	01010-2
1.3	Coordination with the District	01010-4
1.4	Work Sequence	01010-4
1.5	Notifications	01010-4
1.6	Safety and Protection	01010-5
1.7	Special Requirements	01010-5
1.8	Quality Control	01010-6

### MATERIALS, EQUIPMENT AND WORKMANSHIP

#### GENERAL

1.1	Description	01600-1
1.2	Material, Equipment, and Workmanship	01600-1

### DISINFECTION OF DOMESTIC WATER LINES

#### GENERAL

1.1	Description	01656-1
1.2	Product Delivery, Storage and Handling	01656-1

#### PRODUCTS

2.1	Materials	01656-1
-----	-----------	---------

#### EXECUTION

3.1	General	01656-1
3.2	Preliminary Flushing	01656-2
3.3	Methods	01656-2
3.4	Final Flushing	01656-4
3.5	Bacteriological Tests	01656-5
3.6	Repetition of Procedure	01656-5

## **TESTING PIPING SYSTEM**

### **GENERAL**

1.1	Description	01666-1
1.2	Hydrostatic Pressure Test	01666-2
1.3	Passing	01666-2

## **SITE CLEANUP**

### **GENERAL**

1.1	Description	01710-1
1.2	Execution	01710-1
1.3	Disposal	01710-2

## **PROJECT RECORD DRAWINGS**

### **GENERAL**

1.1	Certified Recording of Drawings	01720-1
1.2	Maintenance of Project Record Drawings	01720-1
1.3	Submission	01720-2

## **TRENCHING, BACKFILLING AND COMPACTING**

### **GENERAL**

1.1	Description	02221-1
1.2	Quality Assurance	02221-1
1.3	Job Conditions	02221-2
1.4	Maintenance and Correction	02221-4

### **MATERIALS**

2.1	Stabilization Material	02221-4
2.2	Bedding Zone Materials	02221-4
2.3	Ground Water Barriers	02221-6
2.4	Trench Backfill Material	02221-6

## **EXECUTION**

3.1	Preparation	02221-7
3.2	Trenching	02221-7
3.3	Pipe Bedding	02221-8
3.4	Ground Water Barriers	02221-9
3.5	Backfilling and Compaction	02221-9
3.6	Field Quality Control	02221-10

## **PIPE BORING AND JACKING**

### **GENERAL**

1.1	Description	02224-1
1.2	Quality Assurances	02224-1

### **PRODUCTS**

2.1	Casing Pipe - Smooth Steel	02224-1
2.2	Accessories	02224-2

### **EXECUTION**

3.1	Casing Installation	02224-3
3.2	Carrier Pipe Installation	02224-4
3.3	Cathodic Protection	02224-4

## **PAVEMENT REPAIR AND RESURFACING**

### **GENERAL**

1.1	Description	02575-1
-----	-------------	---------

### **MATERIALS**

2.1	Aggregate, Asphalt and Concrete	02575-1
-----	---------------------------------	---------

### **EXECUTION**

3.1	Manhole Frames and Valve Boxes	02575-1
3.2	Asphalt and Concrete, Base and Gravel Surfaces	02575-2
3.3	Field Quality Control	02575-2

## **DUCTILE IRON PIPE**

### **GENERAL**

1.1	Description	02615-1
1.2	Product Delivery, Storage and Handling	02615-1

### **PRODUCTS**

2.1	Ductile Iron Pipe	02615-2
2.2	Fittings and Couplings	02615-2
2.3	Joints	02615-3
2.4	Tracing Wire	02615-3
2.5	Pipe Lining	02615-3
2.6	Pipe Coating	02615-4
2.7	Accessories	02615-4

### **EXECUTION**

3.1	Installation	02615-4
-----	--------------	---------

## **PLASTIC PRESSURE PIPE**

### **GENERAL**

1.1	Description	02622-1
1.2	Product Delivery, Storage and Handling	02622-1

### **PRODUCTS**

2.1	Plastic Pressure Pipe	02622-2
2.2	Fittings and Couplings	02622-2
2.3	Joints	02622-3
2.4	Tracer Wire	02622-3
2.5	Accessories	02622-3

### **EXECUTION**

3.1	Installation	02622-4
-----	--------------	---------

## **VALVES**

### **GENERAL**

1.1	Description	02641-1
1.2	Product Delivery, Storage and Handling	02641-1

### **PRODUCTS**

2.1	General	02641-1
2.2	Gate Valves	02641-1
2.3	Tapping Valves	02641-2
2.4	Butterfly Valves	02641-2
2.5	Valve Boxes	02641-3
2.6	Air Relief/Vacuum Relief Valves	02641-4
2.7	Check Valves	02641-5

### **EXECUTION**

3.1	Installation	02641-5
3.2	Air Relief/Vacuum Relief Valves	02641-6
3.3	Pressure Relief Valves	02641-6
3.4	Operation	02641-6

## **FIRE HYDRANTS**

### **GENERAL**

1.1	Description	02644-1
1.2	Product Delivery, Storage and Handling	02644-1

### **PRODUCTS**

2.1	General	02644-1
2.2	Materials and Construction	02644-2
2.3	Hydrant Gravel	02644-3

### **EXECUTION**

3.1	Installation	02644-3
3.2	Operation	02644-4

## **SERVICE LINES METERS AND APPURTENANCES**

### **GENERAL**

1.1	Description	02646-1
1.2	Product Delivery, Storage and Handling	02646-1
1.3	Installation of Service Taps	02646-1
1.4	Maintenance and Correction	02646-2
1.5	Meter Pits and Vaults	02646-2

### **PRODUCTS**

2.1	Tapping Saddles	02646-4
2.2	Corporation Stops	02646-5
2.3	Service Lines	02646-6
2.4	Couplings	02646-6
2.5	Meter Setters	02646-6

### **EXECUTION**

3.1	General	02646-7
3.2	Service Line Taps	02646-8
3.3	Service Lines	02646-8
3.4	Meter Pits and Vaults	02646-9
3.5	Inspection	02646-9

## **WATER DISTRIBUTION SYSTEM**

### **GENERAL**

1.1	Description	02713-1
1.2	Quality Assurance	02713-1
1.3	Product Delivery, Storage and Handling	02713-1
1.4	Job Conditions	02713-1

## **PRODUCTS**

2.1	Pipe	02713-2
2.2	Valves	02713-2
2.3	Fire Hydrants	02713-2
2.4	Blow-Offs	02713-2
2.5	Service Lines, Meters and Appurtenances	02713-3
2.6	Tapping Sleeves	02713-3
2.7	Concrete Vaults and Manholes	02713-3

## **EXECUTION**

3.1	Inspection	02713-5
3.2	Preparation	02713-5
3.3	Pipe Installation	02713-6
3.4	Concrete Thrust Restraint (by approval only)	02713-7
3.5	Installations of Pipeline Appurtenances	02713-8
3.6	Fire Lines	02713-9
3.7	Cross Connection Control	02713-9
3.8	Protection of Metal Surfaces	02713-9

## **CAST - IN - PLACE CONCRETE**

### **GENERAL**

1.1	Description	03300-1
-----	-------------	---------

### **MATERIALS**

2.1	Cement	03300-1
2.2	Aggregates	03300-1
2.3	Water	03300-1
2.4	Admixtures	03300-1
2.5	Concrete Reinforcement	03300-2

### **CONCRETE**

3.1	General	03300-2
3.2	Placing	03300-3
3.3	Finishing	03300-3
3.4	Curing	03300-3



## **PRECAST CONCRETE**

### **GENERAL**

1.1	Description	03400-1
1.2	Product Delivery, Storage and Handling	03400-1

### **PRODUCTS**

2.1	Precast Concrete Products	03400-1
-----	---------------------------	---------

## **APPENDIX**

## SECTION 01010

### SUMMARY OF WORK

#### PART 1 - GENERAL

##### 1.1 SCOPE

- A. The purpose of this document is to present the Fort Collins - Loveland Water District's criteria for the construction of twelve (12) inch and smaller water mains, water services and all appurtenances associated with these mains and services. It is for the use of Owners, Developers, Design Engineers, and Contractors as guidelines for the construction of said mains, services, and appurtenances. Please inform the District of any errors, mistakes, discrepancies, spelling errors or grammatical errors.
  - 1. In the case of water mains which are larger than twelve (12) inch, the Owner, or the Owner's representative, shall submit construction specifications to the District for review, prior to approval of construction drawings. The basis for developing these specifications shall be this document.
  
- B. These specifications are intended to be sufficiently detailed to provide adequate definition of the work to be performed and to insure the quality of that work.
  - 1. The Contractor and/or his representative shall be responsible for understanding the provisions and the content of these Specifications.
  
- C. These specifications are composed of written Material Specifications and Typical Drawings. The interpretation of these specifications shall be made by the Fort Collins - Loveland Water District.
  - 1. Every attempt shall be made to avoid conflicts between the standards and drawings during design. However, when requested in writing the Fort Collins - Loveland Water District shall provide a letter of interpretation.
  
- D. In the event that a conflict occurs between water mains, services, and other utilities, as identified during construction, the Contractor shall contact the Fort Collins - Loveland Water District to interpret these specifications or to determine if the standards of other utilities or departments apply.

## **1.2 SPECIFICATION DOCUMENTS**

### **A. Definitions.**

1. AASHTO - American Association of State Highway and Transportation Officials.
2. ACI - American Concrete Institute.
3. ANSI - American National Standards Institute.
4. ASTM - American Society for Testing and Materials.
5. AWWA - American Water Works Association.
6. CDOH STANDARDS - Colorado Department of Highways Standard Specifications for Road and Bridge Construction.
7. CONTRACTOR - An individual who has entered into an Agreement with the Owner to perform the work.
8. CONSTRUCTION DRAWINGS - Detailed and working drawings, including plan, profile, and detail sheets of proposed utility improvements, approved by the Engineer.
9. DESIGN ENGINEER - The partnership, corporation, or individual who is registered as a professional engineer, according to Colorado statutes, and who is hired by the owner, and is empowered to act as his agent for the project.
10. DISTRICT ENGINEER - Shall mean the District Engineer of the Fort Collins - Loveland Water District or their authorized representative.
11. DISTRICT - The Fort Collins - Loveland Water District
12. OSHA - Occupational Safety and Health Administration.
13. OR AN APPROVED EQUAL - As approved, in writing, to being equal by the District.
  - a. Reference Section 01600.
14. OWNER - The developer, corporation, association, partnership, or individual who has entered into an agreement with the District and has entered into an agreement with the contractor to perform the work.

15. PROVIDE - Furnish and install complete in place.
16. RECORD DRAWINGS - Detailed drawings that show actual construction and contains field dimensions, elevations, details, changes made to the construction drawings by modification, details which were not included on the construction drawings, and horizontal and vertical locations of underground utilities.
  - a. Record Drawings are usually construction drawings which have been modified to contain the information listed above.
17. REMOVE - Remove and dispose of in a manner consistent with local ordinances, laws and regulations.
18. SERVICE LINE - All pipe, fittings and appurtenances for conveying water from the distribution mains to the premises and/or meter as applicable.
19. SHALL - A mandatory condition.
20. TAP - The physical connection to the distribution main.
21. UTILITY - District Manager or his authorized representative.
22. WORK - The entire completed construction or the various separately identifiable parts required to be furnished for the project. Work is the result of performing services, furnishing the labor and furnishing and incorporating materials and equipment into the construction.

B. Interpretation

1. These Specification's contain many command sentences which are directed at the Contractor unless otherwise stated.
2. The Contractor shall request clarification, in writing to the District, of all apparent conflicts. The District will not be responsible for any explanations, interpretations, or supplementary data provided by others.
3. Most recent issue of standards.

### **1.3 COORDINATION WITH THE DISTRICT**

- A. The Developer\Developer's Representative\Contractor is responsible for coordinating a pre-construction meeting with the District.
- B. The Contractor is responsible for coordinating the work with the District.
- C. Connections to existing pipelines.
  - 1. All connections to existing water mains shall be made at a time authorized by the District.

### **1.4 WORK SEQUENCE**

- A. Contractor shall coordinate the sequence of activities, taking into account work by others; possible easement requirements; permit requirements; and District requirements.
- B. Contractor shall coordinate the beginning of work, excavation near ditches, railroads, road cuts, etc. with the District, affected parties, and utilities prior to beginning construction.
- C. Contractor shall coordinate pipe filling, chlorination testing and pressure testing with the District.

### **1.5 NOTIFICATIONS**

- A. Contractor shall contact the District, all utilities and affected parties at least 48 hours (exclusive of holidays and weekends) prior to working in areas adjacent to underground utilities.
- B. Contractor shall verify vertical and horizontal locations of all existing utilities prior to installation of District facilities.
- C. Contractor shall give the District a minimum of 48 hours notice (exclusive of holidays and weekends) prior to commencement of work, see previous page.
- D. Developer\Developer's Representative\Contractor shall coordinate all inspections, testing, walk-throughs, etc. with the District Representative.

## **1.6 SAFETY AND PROTECTION**

- A. Contractor shall be responsible for initiating, maintaining and supervising all safety precautions and programs in connection with the work. Contractor shall take all reasonable and necessary precautions for the safety of, and shall provide the necessary protection to prevent damage, injury or loss to:
  - 1. Employees and other persons onsite who may be affected.
  - 2. The work and materials or equipment to be incorporated therein, whether in storage on or off the site.
  - 3. Other property at the site or adjacent thereto, including, but not limited to trees, shrubs, lawns, walks, pavements, roadways, structures and utilities not designated for removal, relocation or replacement in the course of construction.
- B. Contractor shall comply with all applicable laws, ordinances, rules, regulations and orders of any public body having jurisdiction for the safety of persons or property or to protect them from damage, injury or loss; and shall erect and maintain all necessary safeguards for such safety and protection.

## **1.7 SPECIAL REQUIREMENTS**

- A. All items and work not covered by these specifications shall be discussed with the District, and the Contractor shall receive approval from the District, in writing, prior to beginning work.
- B. All work must be acceptable by the District prior to being placed in service.
- C. District furnished material.
  - 1. When the District furnishes any materials, the Contractor shall be responsible for such materials once they have been picked up or delivered to the job site.
  - 2. The Contractor shall be responsible for the careful inspection of 'District furnished material' at the time of delivery.
  - 3. Contractor shall repair, in a manner acceptable to the District, or replace any 'District furnished material', which has been damaged or stolen, at the Contractor's expense.
  - 4. The District is responsible for the quality and operational design aspects of 'District furnished material'.

- D. Contractor shall warrant all work, for a period of one (1) year, after final completion and District acceptance of the work.
  - 1. Contractor may perform such maintenance and repairs by subcontract.
    - a. If the Subcontractor chooses to subcontract the warranty work, he shall submit to the District a copy of the subcontract or the work authorization as evidence of the contractor's faithful intention during the one (1) year warranty period.
- E. Field changes from the approved plans shall not be permitted without prior permission from the District.
- F. The Developer, Developer's Engineer or Developer's Contractor is responsible to coordinate a pre-construction meeting with the District at least five (5) days, exclusive of holidays and weekends, prior to construction.
- G. The Developer, Developer's Engineer or Developer's Contractor is responsible to submit three (3) sets of approved Construction Drawings to the District at least five (5) days, exclusive of holidays and weekends, prior to the pre-construction meeting.
- H. The Developer shall be responsible for the cost of re-tests, excessive inspection and inspection during non-office hours. Office hours are 7:00 a.m. to 3:30 p.m. Monday through Friday exclusive of holidays. The District will notify the Contractor when such costs are being incurred.
- I. No work shall take place on weekends or holidays without prior authorization from the District.
- J. Contractor shall provide all materials, equipment and other items required to isolate and accomplish total separation of new construction from existing facilities.
- K. Prior to commencing work, Contractor shall designate, in writing, an authorized representative who shall have complete authority to represent the Contractor and shall be on the construction site at all times during work activities.

## **1.8 QUALITY CONTROL**

### **A. Inspection.**

1. The District shall make periodic checks to verify the quality and progress of the work. The authorized agents and their representatives of the District shall be provided safe access to the work, whenever it is in preparation or progress. The Contractor shall provide for such access and for inspection, including maintenance of temporary and permanent access.
2. Materials and equipment rejected by the District shall be identified and marked for removal for the Contractor or Supplier.

END OF SECTION



## **SECTION 01600**

### **MATERIAL, EQUIPMENT AND WORKMANSHIP**

#### **PART 1 - GENERAL**

##### **1.1 DESCRIPTION**

- A. This section addresses the material, equipment, and workmanship needed to complete the installation of the water main and all associated appurtenances.

##### **1.2 MATERIALS AND EQUIPMENT**

- A. Contractor shall furnish all materials, equipment, labor, and incidentals necessary for the execution, disinfection, testing, and completion of the work.
- B. All materials and equipment shall be of good quality and new, except as otherwise approved by the District.
  - 1. When requested by the District, the Contractor shall furnish satisfactory evidence (including manufacturer's certification) as to the kind and quality of materials and equipment, and their compliance with these specifications.
    - a. The District shall test any manufacturer's material it deems necessary.
    - b. It is the Contractor's responsibility to insure the manufacturer's materials supplied meet these specifications.
  - 2. Prior to using existing materials, written approval must be obtained from the District.
- C. All materials and equipment shall be installed and used in accordance with the instructions of the applicable manufacturer, fabricator, supplier or distributor, except as otherwise provided in these specifications.
- D. The specification of materials and equipment shall be understood to be representative of a quality of performance, operation and construction acceptable to the District.
  - a. Such requests shall include detailed product literature and a description of benefits which might be achieved by this substitution.

- E. In approving materials or equipment for installation, the District assumes no responsibility for injury or claims resulting from failure of the materials or equipment to comply with the applicable National, State, and local safety codes or requirements, or the safety requirements of a recognized agency; or failure due to faulty design concepts, or defective workmanship.

END OF SECTION

## **SECTION 01656**

### **DISINFECTION OF DOMESTIC WATER LINES**

#### **PART 1 - GENERAL**

##### **1.1 DESCRIPTION**

- A. This section addresses the filling and disinfection of potable water distribution lines.
- B. The Contractor is responsible for the disinfection and testing of water lines.

##### **1.2 PRODUCT DELIVERY, STORAGE AND HANDLING**

- A. Reference the Forwards to AWWA B300 and AWWA C651.
- B. Hypochlorite should be handled with extreme care.

#### **PART 2 - PRODUCTS**

##### **2.1 MATERIALS**

- A. Hypochlorite.
  - 1. Reference AWWA B300.
- B. Adhesive.
  - 1. Any adhesive used to adhere hypochlorite tablets to the interior of the pipe shall be a food grade adhesive, which has received US Drug Administration approval for uses that may involve contact with edible products.

#### **PART 3 - EXECUTION**

##### **3.1 GENERAL**

- A. The Contractor, with District approval, shall satisfactorily disinfect and flush new water lines prior to placing them in service, in accordance with AWWA C651.
- B. Filling pipe.
  - 1. The District shall operate existing valves to fill the pipe, open air blow-offs, and hydrants. District personnel shall witness testing and operation.

2. Where permanent air vents are not available, the Contractor shall install corporation stops at high points in the water line, in order to evacuate air.
  - a. All corporation stops, which were installed to facilitate evacuation of air from the water main, shall be removed and plugged after the water main is filled, and prior to pressure testing.

### **3.2 PRELIMINARY FLUSHING**

- A. Preliminary flushing shall not be performed if the tablet or granular method of disinfection is approved by the District.
- B. The pipelines shall be flushed at a minimum velocity of 2.5 ft/sec., in order to remove foreign material prior to disinfection.

### **3.3 METHODS**

#### **A. General.**

1. The District shall:
  - a. Review and approve the disinfection method proposed by the contractor.
  - b. Sample and test water from the pipe system extremities until clear, potable water is obtained.
2. The Contractor shall:
  - a. Propose the method of chlorination
  - b. Properly dispose of flushed water
  - c. Reimburse the District for all costs associated with obtaining water samples for potable water testing.

#### **B. Granular method.**

1. The granular method consists of placing calcium hypochlorite granules in the water main during construction, and filling the main with potable water when installation is completed.
  - a. During construction, calcium hypochlorite tablet / granules shall be placed at the upstream end of the first section of pipe, at the upstream end of each branch main, and in each section of pipe.

- i. The quantity of granules used shall be as shown in Table 1, AWWA C651.
- b. During construction, calcium hypochlorite granules shall be placed in each section of pipe, hydrant, hydrant lateral, and other appurtenances.
  - i. The quantity of granules used shall be as shown in Table 2, AWWA C651.
- c. Granules shall be placed in sufficient number and amount to produce a minimum chlorine concentration in the treated water of 50 milligrams per liter.
- d. Introduce water into the pipes at a velocity no greater than 1 ft. /sec.
- e. The chlorinated water shall be retained in the lines for a minimum of 48 hours, at which time the treated water must contain no less than 25 milligrams per liter of chlorine throughout the entire length of the main. The chlorinated water shall be flushed within five (5) days unless otherwise approved by the District.

C. Continuous-feed method

1. The continuous-feed method of disinfecting water mains consists of placing calcium hypochlorite granules in the main during construction, completely filling the main to remove all air pockets, flushing the completed main to remove the particulates, and filling the main with potable water chlorinated so that after a 24 hour holding period in the main, there will be a free chlorine residual of not less than 10 milligrams per liter.
  - a. Calcium hypochlorite granules shall be placed in the pipe sections during construction.
    - i. Reference Section 3.3.B.1.c.
  - b. Prior to being chlorinated, the main shall be filled to eliminate air pockets, and shall be flushed to remove particulates. The flushing velocity shall not be less than 2.5 feet per second.
    - i. Reference Section 3.2 and AWWA C651.
  - c. Chlorinated water shall be introduced into the water lines at a point approved by the District at a constant, measured rate so that the chlorine concentration is maintained at a minimum of 25 milligrams per liter of free chlorine.

- i. The entire main shall be filled with the chlorine solution.
  - ii. Reference Table 4 of AWWA C651.
  - iii. Prior to and during the disinfection process, valves shall be positioned so that the chlorine solution in the newly constructed main will not flow into water mains in active service.
- d. The chlorinated water shall be retained in the main for a minimum of 24 hours, at which time the treated water in all portions of the main shall have a free residual of not less than 10 milligrams per liter.

### **3.4 FINAL FLUSHING**

- A. After the applicable retention period, the heavily chlorinated water shall be flushed from the water lines until the chlorine measurements show that the concentration in the water leaving the main is no higher than that generally prevailing in the system, or is less than 1 milligram per liter. The Contractor shall be responsible for all necessary permits and to ensure that no environmental damage occurs.
1. Reference Appendix B of AWWA C651, for a list of neutralizing chemicals.

### **3.5 BACTERIOLOGICAL TESTS**

- A. The District shall coordinate sampling from the pipeline after final flushing and pressure testing, but prior to placing water lines in service, to test for bacteriological quality to show the absence of coliform and heterotrophic organisms.
1. The District shall be given a minimum of 48 hours advance notice, prior to collecting samples.
  2. Samples may only be taken Monday – Thursday, exclusive of weekends and holidays.
- B. The number, and location of samples, shall be determined by the District based upon AWWA C651.

### **3.6 REPETITION OF PROCEDURE**

- A. If the initial disinfection fails to produce satisfactory samples, the main shall be re-flushed and re-sampled. If the samples are still not satisfactory, the main shall be re-chlorinated by the continuous-feed method of chlorination until satisfactory results are obtained.
  
- B. If the residual is less than 25 milligrams per liter, the water lines shall be re-chlorinated by the continuous-feed method of chlorination and retested.

END OF SECTION

## SECTION 01666

### TESTING PIPING SYSTEM

#### PART 1 - GENERAL

##### 1.1 DESCRIPTION

- A. This section addresses the hydrostatic testing of water distribution lines and services.
- B. All appurtenances, including services, shall be tested with the main.
- C. Once the pipeline has been filled and disinfected, and backfilling has been completed and approved, a pressure test shall be conducted.
  - 1. The contractor shall provide all equipment and personnel to perform the hydrostatic test.
    - a. Test equipment shall be able to maintain a continuous internal pipe pressure of 150 psi and accurately measure leakage over a two (2) hour minimum test period.
    - b. The maximum allowable pressure gauge increment shall be 5 psi.
    - c. A water meter shall be used to measure the amount of water used in pressurizing the system.
  - 2. The District will record times, leakage readings and pressure over the test period.
- D. Testing shall not occur until at least seven (7) days have elapsed since the last concrete thrust restraint was cast, or until a minimum compressive strength of 2500 psi is achieved.
- E. Testing shall not occur until after the pipeline has been chlorinated and flushed.
- F. The pipe shall remain filled with water for a minimum of 48 hours prior to the hydrostatic pressure test. Chlorinated water for disinfection shall be flushed within five (5) days unless otherwise approved by the District.
- G. Unless otherwise approved by the District, the hydrostatic pressure test shall be performed against all valves within the new piping system, including connections to existing facilities.



## 1.2 HYDROSTATIC PRESSURE TEST

- A. "Leakage" is the quantity of water that must be supplied into the newly laid pipe, or any valved section thereof to maintain a pressure of 150 psi, after the air has been expelled and the pipe has been filled with water.
- B. Test pressure.
  - 1. For ductile iron pipe and PVC pipe, the minimum test pressure shall be 150 psi.
  - 2. A pressure of 150 psi shall be maintained for a minimum of two (2) hours.
- C. The maximum allowable leakage for each test section of ductile iron pipe, and PVC pipe is determined by the following formula:

$$L = \frac{SD(P)^{1/2}}{133,200}$$

where:

L = maximum allowable leakage, in gallons.

S = Length of pipe tested, in feet.

D = nominal pipe diameter, in inches.

P = average test pressure during the leakage test, in psi.

- 1. Reference AWWA C600.
- D. Testing and Leakage.
  - 1. Unless prior permission is given by the District, a test section shall not be any longer than the length of pipe between adjacent line valves.
  - 2. Testing through fire hydrants shall not be allowed, unless approved by the District Representative.
  - 3. The contractor shall provide certification of meter accuracy.

## 1.3 PASSING

- A. If the tests disclose leakage greater than that specified, the defective materials and joints shall be located and repaired.
  - 1. The tests shall be repeated until the leakage is less than the maximum allowed.

- B. With the exception of obvious leaks, passing of the pressure test shall be on the basis of maximum allowable leakage per section tested.
- C. All visible leaks shall be repaired regardless of maximum allowable leakage.

END OF SECTION

## **SECTION 01710**

### **SITE CLEANUP**

#### **PART 1 - GENERAL**

##### **1.1 DESCRIPTION**

- A. Site cleanup shall be executed during the progress of the work, and at the completion of the work.

##### **1.2 EXECUTION**

- A. Construction materials shall be neatly stored.
- B. Containers shall be provided for the collection of wasted material and debris.
  - 1. Containers shall be stored out of the right-of-way.
- C. Volatile wastes shall be stored in clearly marked, covered metal containers and removed daily.
- D. Construction materials, equipment, waste containers, construction buildings, parking, etc., shall only be allowed within the limits of the construction easement.
  - 1. Any off-site storage of construction material, equipment, waste containers, construction buildings, parking, etc. shall be allowed only after the Contractor has obtained the written permission of the property owner.
- E. Upon completion of the construction, the job site shall be restored to its original condition or better.
  - 1. Contractor shall restore any land which will not be paved with asphalt, or concrete, to its original condition.
    - a. All topsoil shall be restored to its original quality.
    - b. Any areas which are stripped of vegetation prior to, or during construction, shall be reseeded.
  - 2. All exterior paved surfaces shall be broom cleaned, and left in good repair.

### **1.3 DISPOSAL**

- A. In order to maintain an orderly site, waste material and debris shall be removed periodically.

END OF SECTION

## **SECTION 01720**

### **PROJECT RECORDS DRAWINGS**

#### **PART 1 - GENERAL**

##### **1.1 CERTIFIED DRAWING OF RECORD**

- A. Certified Record Drawings shall be submitted by the Design Engineer to the District Engineer for review and approval.
- B. Each drawing shall be labeled "DRAWINGS OF RECORD" in neat large printed letters, stamped and signed by a registered P.E. in the State of Colorado.
- C. Construction information shall be recorded concurrently with construction progress.
- D. Record Drawings shall be marked legibly and with an indelible pen.
- E. Record Drawings shall include, as a minimum, the following:
  - 1. Field dimensions, elevations, and details.
  - 2. Changes which are made by modification.
  - 3. Details which are not on the original Construction Drawings.
  - 4. Horizontal and vertical locations of underground utilities and appurtenances, referenced to a minimum of three permanent surface improvements.
  - 5. Depths of various elements of work in relation to project datum.
  - 6. All dimensions shall be referenced to property pins if surface improvements have not been constructed.

##### **1.2 MAINTENANCE OF PROJECT RECORD DRAWINGS DURING CONSTRUCTION**

- A. Record Drawings and any documents used for the preparation of said Drawings shall be stored apart from documents used for construction.
- B. Record Drawings shall be maintained in a clean, dry, legible condition and in good order.

### **1.3 SUBMISSION**

- A. Project Record Drawings shall be submitted to the District Engineer with a transmittal letter containing the following:
  - 1. Date.
  - 2. Project title.
  - 3. Design Engineer's name, address and telephone number.
  - 4. Title and number of each Record Document.
- B. Project Record Drawings shall be submitted on 24" x 36", 3 mil (minimum) reproducible, double-matte Mylar, along with electronic Auto-CAD files on compact disc. The Auto-CAD coordinate system shall be NAD 88 and NAD 83.
- C. The final acceptance of the water lines and appurtenances will not be made until all District requirements are satisfied and the Project Record Drawings are received and accepted by the District.
- D. The District recommends that Project Record Drawings be submitted in blue line form for preliminary approval.

END OF SECTION

## SECTION 02221

### TRENCHING, BACKFILLING AND COMPACTING

#### PART 1 - GENERAL

##### 1.1 DESCRIPTION

- A. This section addresses excavation and trenching; including subsurface drainage, dewatering, preparation of sub grades, pipe bedding, backfilling, compacting, and finish grading for underground pipelines, service lines and appurtenances.
- B. Reference the "Trench and Bedding Typical" in the appendix.

##### 1.2 QUALITY ASSURANCE

- A. Soil compaction tests shall be performed in accordance with:
  - 1. ASTM D 2922 - Standard Test Methods for Density of Soil and Soil-Aggregate in Place by Nuclear Methods.
  - 2. ASTM D 1556 - Standard Test Methods for Density of Soil in Place by the Sand-Cone Method.
- B. Construction Staking.
  - 1. Construction staking shall be performed under the supervision of a licensed land surveyor.
  - 2. All survey notes and construction staking notes shall be entered into bound, hard cover field books.
  - 3. Adequate staking shall be provided to establish acceptable horizontal and vertical control.
  - 4. Offsets shall be staked so that vertical and horizontal alignment may be checked.
  - 5. All survey data, which is developed by the Contractor or the Design Engineer in performing surveys which are required by the work, shall be available to the District for examination and reproduction throughout the construction period.

### **1.3 JOB CONDITIONS**

#### **A. Drainage and Groundwater.**

1. Contractor shall obtain all necessary permits prior to starting dewatering operations.
  - a. If groundwater will be discharged into an irrigation ditch, pond, stream or waterway, or will drain to an irrigation ditch, pond stream or waterway, a Colorado Department of Health dewatering permit will be required.
  - b. Permit applications may take up to 30 days to be reviewed by the Colorado Department of Health.
  - c. Contractor is required to complete and process the Discharge Monitoring Report (DMR) that is typically a part of the dewatering permit.
  - d. Upon finishing the work, the Contractor shall be responsible for completing a Colorado Department of Health Discharge Termination Notice.
2. Water that is encountered in the trench shall be removed to the extent necessary:
  - a. provide firm sub grade.
  - b. permit connections to be made in dry conditions.
  - c. prevent the entrance of water into the pipeline.
3. Surface runoff shall be diverted as necessary to keep excavations and trenches free from water during construction.
4. The excavation or trench shall be kept free from water until the structure, or pipe, to be installed therein, is completed to the extent that no damage from hydrostatic pressure, flotation, or other cause will result.
5. The pipe under construction shall not be used for dewatering.

#### **B. Sequencing.**

1. Pipeline installation shall be performed within 300 linear feet of trench excavation.
  - a. This distance may be amended, with the District's approval, based upon job conditions.



2. Initial trench backfill shall be performed within 300 linear feet of pipeline installation.
  - a. This distance may be amended, with the District's approval, based upon job conditions.
3. Backfill shall be completed, at the end of each day, to the extent that no damage from hydrostatic pressure, floatation, or other cause will result.
4. Where excavation is a hazard to automotive or pedestrian traffic, the amount of open trench and the time duration of that opening is to be minimized.

C. Underground Obstructions.

1. The Design Engineer and/or Contractor shall field verify all Record Drawing information obtained from the District.
2. Contractor shall notify each Utility Owner and request utilities to be field located by surface reference.
  - a. The request for the location of utilities shall be made a minimum of 48 hours prior to trenching or excavation (exclusive of holidays and weekends).
3. The Contractor shall expose and verify the size, location, and elevation of underground utilities and other obstructions, sufficiently in advance of construction to permit changes to be made to the Construction Drawings.
  - a. In the event there is a conflict, the Contractor shall notify the District and the affected utility company.
  - b. In the event there is a conflict, the proposed work may be modified, at the District's discretion.
4. Existing improvements, adjacent property, utilities, trees, and plants that are not to be removed shall be protected from injury or damage resulting from the Contractor's operations.
5. If the Contractor removes any underground obstructions, the following shall apply:
  - a. Drainage culverts may be salvaged, and reused in an appropriate location, if written approval is obtained from the District.
    - i. All other underground obstructions shall be replaced as directed by the affected utility.

- ii. All field drains shall be repaired or replaced to their original condition, or better.

**1.4 MAINTENANCE AND CORRECTION**

- A. Contractor shall maintain and repair all trench settlement, resulting from Contractor negligence, which occurs within the one (1) year warranty period, and make necessary repairs to pavement, sidewalks or other structures which may be damaged as a result of trench settlement.

**PART 2 - MATERIALS**

**2.1 STABILIZATION MATERIAL**

- A. If the existing soil in the trench bottom is judged to be unstable by the District and/or the Contractor, the unstable material shall be removed and replaced with an acceptable stabilization material.
  - 1. The over-excavation depth shall be a minimum of six (6) inches.
  - 2. Stabilization material is crusher-run rock, conforming to ASTM D448, or CDOH #357.

<i>SIZE</i>	<i>PERCENT PASSING</i>
2 1/2"	100
2"	95 - 100
1"	35 - 70
1/2"	10 - 30
#4	0 - 5

- B. Geosynthetics may be used in conjunction with stabilization material, with the prior written approval of the District.

**2.2 BEDDING ZONE MATERIALS**

- A. The bedding zone shall extend from four (4) inches below the invert of the pipe to twelve (12) inches above the pipe.
  - 1. Reference the "Trench and Bedding Typical" in the appendix.

B. Granular material shall be a uniformly graded crushed material, conforming to CDOT #67.

1. CDOT #67

<i>SIZE</i>	<i>PERCENT PASSING</i>
1"	100
3/4"	90 - 100
3/8"	20 - 55
#4	0 - 10
#8	0 - 5

2. If noted on the Construction Drawings, the granular material may be 3/8" chips conforming to CDOT #8.

<i>SIZE</i>	<i>PERCENT PASSING</i>
1/2"	100
3/8"	85 - 100
#4	10 - 30
#8	0 - 10
#16	0 - 5

3. If noted on the Construction Drawings, the granular material may be sand conforming to ASTM C 33.

<i>SIZE</i>	<i>PERCENT PASSING</i>
3/8"	100
#4	70 - 100
#8	36 - 93
#16	20 - 80
#30	8 - 65
#50	2 - 30
#100	1 - 10

C. Select soil shall be either trench backfill material (which is free of rocks, clods, stones greater than 1-1/2 inches in any dimension, and which meets the other requirements of trench backfill material), or granular material.

**2.3 GROUND WATER BARRIERS**

- A. If compacted soil is used for ground water barriers, it shall meet the following soil classification.
  - 1. SC - clayey sands, sand-clay mixtures.
  - 2. CL - inorganic clays of low to medium plasticity, gravelly clays, sandy clays, silty clays, lean clays.
  - 3. CH - inorganic clays of high plasticity, fat clays.
- B. Concrete used for ground water barriers shall develop a minimum compressive strength of 2,000 psi after twenty eight (28) days. Concrete ground water barriers must be approved, in writing, by the District.

**2.4 TRENCH BACKFILL MATERIAL**

- A. Trench backfill material shall be placed from a point twelve (12) inches above the pipe to twelve (12) inches below the ground surface or to the bottom of the pavement sub grade, whichever is greater.
- B. Trench backfill material shall be either soil excavated from the trench, or imported soil.
  - 1. Any soil used for trench backfill, shall be free from frozen matter, stumps, roots, brush, other organic matter, cinders or other corrosive material, debris, and any rocks or stones which are larger than six (6) inches, in any dimension.
    - a. Rocks or stones which are six (6) inches or larger may be used in trench backfill material with prior written approval of the District.
  - 2. If imported soil is used for trench backfill, it shall meet CDOT specifications for Class #1 structural backfill.

<i>SIZE</i>	<i>PERCENT PASSING</i>
2"	100
#4	30 - 100
#50	10 - 60
#100	5 - 20

## **PART 3 - EXECUTION**

### **3.1 PREPARATION**

- A. Topsoil shall be stripped from areas which are to be disturbed by construction, and stockpiled.
  - 1. Topsoil shall be segregated from non-organic trench excavation material, and debris.

### **3.2 TRENCHING**

- A. Trenches shall be excavated by open cut methods, except where boring or tunneling is shown on drawings, or approved by the District.
- B. Care shall be used when operating mechanical equipment in locations where it may cause damage to trees, buildings, culverts, or other existing property, utilities, or structures above or below ground.
- C. Mechanical equipment shall be operated in such a manner that the bottom elevation of the trench can be maintained with uniform trench widths and vertical sidewalls of the bedding zone.
- D. Trench alignment shall be sufficiently accurate to permit pipe to be aligned properly with an eight (8) inch minimum clearance between the pipe and the sidewalls of the trench or trench box.
  - 1. The trench sidewall shall not be undercut in order to obtain clearance.
- E. Preparation of trench bottom.
  - 1. Trench bottom shall be graded uniformly to provide clearance for each section of pipe.
  - 2. Loose material, water, and foreign objects shall be removed from the trench.
  - 3. The Contractor shall provide a firm sub grade, which is suitable for placement of bedding material.
  - 4. If the trench bottom is judged to be unstable by the District and/or the Contractor, the unstable material shall be removed and replaced with an acceptable stabilization material.
    - a. The over-excavation depth shall be a minimum of 6-inches.

- b. Reference paragraph 2.1.
- 5. The Contractor shall over-excavate a minimum of six inches below the bottom of the pipe wherever the trench bottom is rock, or other unsuitable material.
- 6. Over-excavation shall be backfilled and compacted with acceptable Stabilization Material.
  - a. Reference paragraph 2.2 A.
- F. Stockpiling excavated materials.
  - 1. Suitable material for backfilling shall be stockpiled in an orderly manner, and stored a minimum of two (2) feet from the edge of the trench.
  - 2. Excess excavated materials not suitable or not required for backfilling shall be disposed of away from the immediate work area.
  - 3. Excavated material shall not be stockpiled against or over existing structures or appurtenances.

### **3.3 PIPE BEDDING**

- A. Placement and compaction.
  - 1. Reference the "Trench and Bedding Typical" in the appendix.
  - 2. Bedding material shall be distributed and graded to provide uniform and continuous support beneath the water main at all points between bell ends, or pipe joints.
    - a. Pipe shall not be supported by the bells.
    - b. A minimum of four (4) inches of bedding shall be placed prior to the installation of the pipe.
  - 3. To prevent lateral displacement, granular bedding material shall be deposited and compacted uniformly and simultaneously on each side of the pipe.
    - a. Bedding material shall not be dropped onto unsupported pipe.
  - 4. Granular bedding material shall be consolidated under and around the pipe.

### **3.4 GROUND WATER BARRIERS**

- A. Ground water barriers shall be constructed in such a manner as to impede passage of water through bedding material for the full depth of the granular bedding material, and the full width of the trench.
  - 1. Ground water barriers shall be approximately four (4 - 8) feet long and spaced not more than four hundred (400) feet apart.
  - 2. Both sides and the bottom of ground water barriers shall be keyed one (1) foot into existing soil, and extend up to original onsite material, or to within one (1) foot of finished grade.

### **3.6 BACKFILLING AND COMPACTION**

- A. All trench backfill shall be compacted.
  - 1. Backfill of pipe and appurtenances and around vaults and valve boxes shall be compacted with equipment and in a manner which is capable of producing the required results.
- B. Backfill material shall be deposited in uniform horizontal layers which shall not exceed six (6) inches (compacted depth), in all areas, unless otherwise approved by the District.
- C. Methods and equipment which are appropriate for the backfill of material shall be utilized.
  - 1. Backfill equipment or backfilling methods which may damage the pipe shall not to be used.
- D. Compaction shall not be performed by jetting or water settling.
- E. Sheeting removal (if Contractor elects to use sheeting).
  - 1. Do not remove sheeting prior to backfilling.
  - 2. Use effective methods to protect the construction, other structures, utilities and property during the sheeting removal.
  - 3. Voids left by sheeting removal shall be filled with dry sand.
  - 4. Unless otherwise approved by the District, sheeting that is left in place shall be cut off at an elevation six (6) feet below finish grade.

- F. Topsoil shall be replaced to the depth of stripping over all areas which are to be reseeded.
- G. Excess excavated material and materials not suitable for backfill shall be disposed of properly.

### **3.7 FIELD QUALITY CONTROL**

- A. This section applies to all water lines and appurtenances that are maintained by the District, and located within public right-of-way, or within easements on private property.
- B. Field moisture/density control.
  - 1. Field tests will be conducted to determine compliance of moisture/density requirements in accordance with ASTM D 2922 (Tests for Density of Soil and Soil-Aggregate in Place by Nuclear Methods).
  - 2. Moisture/density tests are the responsibility of the Contractor, and shall be performed by a private Geotechnical Consultant.
    - a. The method of testing of the compacted material and the validity of the results shall be the responsibility of the Geotechnical Consultant.
    - b. Test results shall be submitted to the District by the Contractor or the Geotechnical Consultant within 24 hours of the test, or by the end of the next working day.
      - i. Copies of the field work sheets are acceptable.
    - c. Summarized test results shall be submitted to the District prior to the initial acceptance of the water system.
  - 3. Moisture/density tests shall be performed at a depth of two (2) feet above the top of the pipe bedding and in two (2) foot increments up to the final grade.
  - 4. Moisture/density tests shall be performed at a minimum of two hundred (200) linear feet, as measured along the length of the pipe, or as determined by the District.
  - 5. Moisture/density tests in the vicinity of vaults and valve boxes shall be performed at a maximum of one (1) foot away from the vault sections or valve box.
    - a. Tests shall be performed in random directions from the vault or valve box, on separate lifts.



- b. A minimum of one (1) test shall be performed for every two (2) feet of backfill material.
- 6. Moisture/density tests shall be performed below the finished subgrade, and a minimum of one time for each service line installed, unless otherwise specified by the District Engineer.
- 7. All failed test areas shall be re-compacted and retested.
- B. Compaction shall be to the following minimum densities: (Reference ASTM D 698 or AASHTO T99 unless otherwise indicated).
  - 1. Ground water barrier material: 95% of maximum density (ASTM D 698).
  - 2. Pipe bedding.
    - a. Compacted granular material: 80% of relative density (ASTM D 4253 and D 4254).
  - 3. Bedding zone: 90% of maximum dry density.
  - 4. Trench backfill.
    - a. Paved roadways, sidewalks and other areas which are to be paved: 95% of maximum dry density.
    - b. Gravel roadways: 95% of maximum dry density.
    - c. Fields and landscaped areas: 90% of maximum dry density.
    - d. Under footings, foundations or structures: 100% of maximum dry density.
    - e. All other locations: 95% of maximum dry density.

C. Moisture content.

1. All compacted backfill shall be within 2% (+/-) of the optimum moisture content of the soil as determined by ASTM D 698. Variances may be requested by submitting a report and recommendation from a private Geotechnical Consultant accompanied with a letter that specifically identifies the variance. Submittals should be directed to the District Engineer.
2. Water shall be added to the material, or the material shall be harrowed, disked, bladed, or otherwise worked to insure uniform moisture content, as specified.

END OF SECTION

## SECTION 02224

### PIPE BORING AND JACKING

#### PART 1 - GENERAL

##### 1.1 DESCRIPTION

- A. This section is a minimum guideline and addresses the furnishing and the installation of casing pipe, either by boring or jacking.
- B. Each casing pipe installation shall be specifically designed by the Design Engineer.
- C. Reference the "Typical Pipe Casing" in the appendix.

##### 1.2 QUALITY ASSURANCES

- A. Design Criteria.
  - 1. Specified thickness for pipe and casings are based upon the superimposed loads and not upon the loads which may be placed on the pipe as a result of jacking operations.
    - a. Increased pipe strength shall be provided as necessary to withstand jacking loads.
- B. Construction Criteria.
  - 1. Owner/Contractor shall obtain the necessary permits from the appropriate agencies, prior to commencing construction.
  - 2. Owner/Contractor shall obtain the bonds or the indemnity which are required by the permits, for protection against any damage and interference with traffic and service, which are caused by the construction activities.
  - 3. All excavations shall conform to the trenching, backfilling and compaction requirements set forth in Section 02221.

#### PART 2 - PRODUCTS

##### 2.1 CASING PIPE - SMOOTH STEEL

- A. The minimum yield point of smooth steel casing pipe shall be 35,000 psi.

- B. Smooth steel casing pipe shall conform to ASTM 139, Grade B (No hydro).
  - 1. Clean used pipe which is in good condition, and conforms to the requirements of this specification may be used with the prior approval of the Design Engineer and District.
- C. The minimum wall thickness of smooth steel casing pipe shall be determined by the agency granting the crossing permit.
  - 1. Reference the "Typical Pipe Casing" in the appendix.
- D. The ends of smooth steel casing pipe shall be beveled for field welding.
  - 1. All field welds shall be painted with an epoxy polyamide exterior coating, or a coal-tar enamel exterior coating, which conforms to AWWA C203, Section 2.
    - a. The minimum thickness of the exterior coating shall be sixteen (16) mil.
- E. Smooth steel casing pipe shall have an epoxy polyamide exterior coating, or when required by the Construction Drawings, a coal-tar enamel exterior coating.
  - 1. If the Contractor elects to omit the exterior coating, 1/16 inch shall be added to the required thickness of the casing pipe.

## **2.2 ACCESSORIES**

- A. Casing Seals.
  - 1. Casing seals shall be constructed of high density rubber with stainless steel straps.
    - a. The acceptable type and manufacturer of high density rubber casing seals are:
      - i. Link-Seal modular seal, model "C" or "S" wrap around end seal with stainless steel bands, Pipeline Seal and Insulator, Inc.
      - ii. Or an approved equal.
- B. Casing chocks.
  - 1. Casing chocks shall be twelve (12) inches in length with stainless steel bodies and polymer runners. There shall be three (3) per joint.

- a. Acceptable manufacturers are:
  - i. Cascade Water Works.
  - ii. Power Seal.
  - iii. An approved equal.
2. The carrier pipe barrel shall be supported in accordance with the "Typical Pipe Casing ", see appendix, and as modified on the approved Construction Drawings.

C. Joint Restraints

1. Joint restraint is required on the carrier pipe joints in accordance with the “Standard Pipe Casing Details”, see appendix, and as modified on the approved Construction Drawings.
  - a. Acceptable Manufacturers are:
    - i. Romac 611 Series.
    - ii. EBAA 1900 Series.
    - iii. Star 1100 Series.
    - iv. Or an approved equal.

**PART 3 - EXECUTION**

**3.1 CASING INSTALLATION**

A. General.

1. Vertical and horizontal offset staking shall be provided at both ends of bored or jacked crossings.
2. Casing pipe shall be installed at the grade and alignment shown on the Construction Drawings.
  - a. Grade and alignment shall not deviate by more than 0.3 feet from that shown on the Construction Drawings.
3. Casing pipe shall be installed as indicated in the Construction Drawings, whether that is by open trench excavation or by jacking methods.

- a. Open trench installation of the casing pipe shall be in accordance with Section 02221.
  4. The earth which is displaced by the casing pipe shall be disposed of properly.
- B. Smooth Steel Pipe.
1. Contractor shall provide a smooth, continuous, and uniform casing pipe with no exterior voids.
  2. Each section of casing pipe shall be welded with a full penetration butt weld around the entire circumference of the joint to form a watertight continuous conduit capable of resisting all stresses, including jacking stresses.
  3. A seventeen (17) pound high potential magnesium anode shall be installed at each end of the casing pipe, using a cadweld method.
- C. Grouting.
1. All spaces between the casing pipe and the earth shall be filled with grout.
    - a. Grout connections on the interior of the casing pipe shall be provided at ten (10) feet (O.C.) intervals.
  2. Grouting operations shall be performed in a sequence which will preclude any deflections which exceed 5 per cent of the tunnel diameter.
  3. After the grout is in place, each hole shall be plugged in order to prevent the backflow of grout.

### 3.2 **CARRIER PIPE INSTALLATION**

- A. Carrier pipe shall be installed at the grade shown on the Construction Drawings.
- B. Each section of pipe shall have a minimum of three (3) casing chocks.
- C. Carrier pipes that exceed 20 L.F. shall have mechanical joint restraints installed at each joint.
- D. The annular space between the casing and the carrier pipes shall be left vacant.
- E. The ends of the casing pipe shall be sealed with casing seals.

### 3.3 CATHODIC PROTECTION

#### A. Soil-Test Evaluation

1. In all cases the Design Engineer must have a certified Geotechnical Engineer perform a soil-test evaluation in strict accordance with AWWA C105, Appendix A. The results and recommendations of the evaluation shall be submitted to the District for consideration and review.
2. The Water-Saturated Soil Box method shall be used to measure the resistivity of the soil.
3. The distance between sample locations shall be at the discretion of the District.
4. If the soil-test evaluation concludes that the soil is corrosive to steel casing pipe, the Design Engineer must submit a comprehensive plan with a proposed design for cathodic protection. The design shall be in accordance with the National Association of Corrosion Engineers (NACE RP0169 latest revisions).

#### B. Magnesium Anodes

1. One anode shall be installed at each end of the casing pipe.
2. Anodes shall be installed vertically in native soils, a minimum of three feet laterally from the pipe to be protected.
3. Place the top of the anode below the centerline of the pipe. However, anode spacing and lateral distance can be adjusted to maintain adequate clearance from permanent structures and obstacles with the approval of the District.
4. Anodes shall be backfilled and tamped with native soil in 6 inch layers. Sand is not permissible.
5. Wet down each anodes with 5 gallons, minimum, of fresh water after backfilling and tamping.

#### C. Wiring

1. Underground wires, cables and connections shall be buried with 6 inch minimum separation from other underground structures.

2. Splices and repairs to damaged cable associations with a cathodic protection system shall be sealed against moisture penetration using 2-1/2 lapped layers of tape alternating between rubber and plastic tape.
3. Wiring shall be backfilled with material free from rocks and debris that could damage the insulation.

D. Brazing (cadweld)

1. Brazing techniques shall comply with the anode manufacture's recommendations. Only proper size cartridges and welders will be permissible.
2. Prior to brazing, an area of the structure three inches square shall be cleaned to bright metal with a grinder or file.
3. The slag shall be removed from the completed braze with a hammer.
4. The adequacy of each braze shall be demonstrated by gently striking the top of the connection with a one pound hammer.
5. The cleaned piping surface, including the brazed connection and exposed copper wire, shall be coated with a coal tar compound.

E. Test Stations

1. Wires shall be brought to the surface and terminated in a CP test station.
2. Test Station shall not be located in traffic or pedestrian areas.
3. Provide a minimum of 48 inches of slack, coiled in each box.
4. Acceptable manufactures are:
  - a. NM-4, C.P. Test Services.
  - b. An approved equal.

END OF SECTION



## SECTION 02575

### PAVEMENT REPAIR AND RESURFACING

#### PART 1 - GENERAL

##### 1.1 DESCRIPTION

- A. This section addresses surface obstructions which the Contractor must remove and replace, such as pavement, drives, curbs, gutters, sidewalks, and similar surfaces, as required to perform the work.
- B. The words *Standard Street Specifications*, as used herein, refer to the current Design Criteria and Standards for Streets of the agency having jurisdiction.

#### PART 2 - MATERIALS

##### 2.1 AGGREGATE, ASPHALT AND CONCRETE

- A. All materials and workmanship, such as but not limited to aggregate, bituminous material, and concrete, which are used in the repair of surface obstructions, shall conform to the specifications of the agency having jurisdiction. Contact the District for specifications if jurisdiction has not been established.

#### PART 3 - EXECUTION

##### 3.1 MANHOLE FRAMES AND VALVE BOXES

- A. Prior to placing the base course, manhole frames and water valve boxes shall be raised to final grade. Manholes/vaults shall be adjusted using a minimum of 4" and a maximum of 8" of HDPE adjustment rings. The adjustment rings shall be installed in accordance with the manufacturer's recommendations.
- B. All foreign matter shall be removed from the manholes and valve boxes immediately.
- C. All valve boxes and manhole covers shall be straight and properly aligned.
  - 1. Valve boxes shall be inspected by placing a valve key on the operating nut to assure a proper alignment and that the valve box is plumb.

### **3.2 ASPHALT AND CONCRETE, INCLUDING BASE AND GRAVEL SURFACING**

- A. The Contractor shall remove, dispose of, and restore asphalt, concrete pavement, curbs, drives, sidewalks and gravel surfacing in accordance with the *Standard Street Specifications*.
  - 1. Contractor shall repair any damage to existing pavement, curbs, drives, or sidewalks which was caused by the work, as shown on the Construction Drawings or as directed by the District.
- B. Concrete drives, curbs, gutters, sidewalks, and similar structures shall be removed, disposed of, and restored in accordance with the agency having jurisdiction. The following minimum thicknesses shall apply if jurisdiction has not been established:
  - 1. Driveways and slabs shall be a minimum six (6) inches thick.
  - 2. Patios shall be a minimum four (4) inches thick.
  - 3. Gutters shall be a minimum six (6) inches thick.
  - 4. Concrete bases for brick pavers and concrete pavement shall be a minimum six (6) inches thick.
  - 5. Sidewalks shall be a minimum six (6) inches thick.
  - 6. Cross pans shall be a minimum eight (8) inches thick.
- C. Reference Section 03300.

### **3.3 FIELD QUALITY CONTROL**

- A. Reference the *Standard Street Specifications* of the agency having jurisdiction.

END OF SECTION

## **SECTION 02615**

### **DUCTILE IRON PIPE**

#### **PART 1 - GENERAL**

##### **1.1 DESCRIPTION**

- A. This section addresses ductile iron pipe. District approval is required for the use or installation of ductile iron pipe.
- B. Pipe shall be furnished complete with all fittings, flanges, specials and other accessories.

##### **1.2 PRODUCT DELIVERY, STORAGE AND HANDLING**

- A. Handling
  - 1. Slings, pipe tongs or skids shall be used for handling pipe.
  - 2. Pipe or fittings shall not be dropped.
  - 3. Care must be taken to prevent damage to the pipe and fittings by impact, bending, compression, or abrasion.
  - 4. Damaged pipe or fittings shall not be installed.
- B. Storage
  - 1. Lubricant shall not be stored and used in a manner which will contaminate the lubricant.
  - 2. Rubber gaskets shall be stored in a location which protects them from deterioration or damaged.
  - 3. The maximum stacking heights of pipe as listed in AWWA C600 shall not be exceeded.

## **PART 2 - PRODUCTS**

### **2.1 DUCTILE IRON PIPE**

- A. All ductile iron pipe, with push-on joints, shall be manufactured in accordance with ANSI A21.51-86(AWWA C151)
- B. All ductile iron pipe, with flanged, flat faced joints, shall be manufactured in accordance with ANSI A21.15-83(AWWA C115).
- C. Ductile iron pipe which is twelve (12) inches and smaller in diameter shall have a working pressure rating of 350 psi.
- D. Ductile iron pipe which is larger than twelve (12) inches in diameter shall have a working pressure rating of 250 psi.
- E. Flanged ductile iron pipe with threaded flanges shall be Class 53 pipe.
- F. All ductile iron pipe shall have nominal laying lengths of either eighteen (18) or twenty (20) feet.
  - 1. Random pipe lengths are not acceptable, except when using restrained joint pipe.

### **2.2 FITTINGS AND COUPLINGS**

- A. All fittings and couplings shall be manufactured in accordance with AWWA C104, C110, and C111.
- B. All fittings and couplings shall have one of the following types of connections:
  - 1. Flanged joint.
  - 2. Mechanical joint with mechanical restraints.
- C. All fittings and couplings shall be made of either gray-iron or ductile iron, and have a minimum working pressure rating of 250 psi.

## **2.3 JOINTS**

- A. All mechanical and push-on joints shall be manufactured in accordance with ANSI A21.11-85(AWWA C111).
  - 1. Unless specified otherwise, all gaskets shall be as recommended by the manufacturer.
  - 2. Lubricant shall be that which is specified by the pipe manufacturer.
  - 3. All nuts and bolts shall be high-strength low-alloy COR-TEN, manufactured in accordance with ANSI-A21.11-85(AWWA C111).
- B. All ductile iron pipe with threaded flanged joints shall be manufactured in accordance with ANSI A21.15-83(AWWA C115).
  - 1. All flanges shall be sized and drilled in accordance with ASME/ANSI B16.1: Cast Iron Pipe Flanges and Flanged Fittings, Class 125.

## **2.4 TRACING WIRE**

- A. Tracing wire shall be a single, 12 gauge, insulated solid copper wire buried directly with the pipe.
- B. Tracing wire will be connected at all piping intersections to form one continuous system. Connections will need to be water tight.
- C. Tracing wire will surface into a test station at all Fire Hydrant locations. Additional locations may be required depending on available Fire Hydrant locations.
- D. Test stations shall not be located in traffic or pedestrian areas.
- E. Acceptable test stations are:
  - 1. NM-4, C.P. Test Services
  - 2. Approved Equal

## **2.5 PIPE LINING**

- A. All ductile iron pipe shall have a standard thickness cement mortar lining.
  - 1. Ductile iron pipe which is twelve (12) inches and smaller in diameter shall have a cement mortar lining with a minimum thickness of 1/16 inch.

2. Ductile iron pipe which is larger than twelve (12) inches in diameter shall have a cement mortar lining with a minimum thickness of 3/32 inch.

B. All ductile iron pipe lining shall conform to ANSI A21.4-85(AWWA C104).

## **2.6 PIPE COATINGS**

A. All ductile iron pipe shall have a bituminous coating on the pipe exterior, unless otherwise specified.

1. The minimum thickness of the bituminous coating shall be one (1) mil.

## **2.6 ACCESSORIES**

A. Joint restraining devices.

1. Push-on and mechanical joints may be restrained with the use of:

- a. Megalugs, EBAA Iron Inc.
- b. Uni-Flange, Uni-Flange Corp.
- c. Approved equal

B. Polyethylene encasement.

1. The polyethylene used in polyethylene encasement shall conform to ASTM D 1248.
2. The minimum thickness of the polyethylene shall be 8 mil.
3. Polyethylene encasement shall be installed in accordance with ANSI A21.5/AWWA C105.

## **PART 3 - EXECUTION**

### **3.1 INSTALLATION**

A. Reference Part 3 of Section 02713.

END OF SECTION

## SECTION 02622

### PLASTIC PRESSURE PIPE

#### PART 1 - GENERAL

##### 1.1 DESCRIPTION

- A. This section addresses plastic pressure pipe and includes the acceptable materials and construction practices which may be used in the installation of plastic pressure pipe.
  - 1. All pipe shall be furnished complete with all fittings, specials, and other accessories.

##### 1.2 PRODUCT DELIVERY, STORAGE AND HANDLING

- A. Handling.
  - 1. Pipe shall not be handled in a manner which will cause damage to the pipe.
  - 2. Pipe or fittings shall not be dropped.
  - 3. Care must be taken to prevent damage to the pipe and fittings by impact, bending, compression, or abrasion.
  - 4. Damaged pipe or fittings shall not be installed.
- B. Storage.
  - 1. Lubricant shall not be stored or handled in a manner which will cause contamination to the lubricant.
  - 2. Rubber gaskets shall be stored in a location which protects them from deterioration.
  - 3. Pipe shall be stored in accordance with the manufacturer's specifications.
  - 4. Pipe shall be stored on a surface which provides even support for the pipe barrel.
    - a. Pipe shall not be stored in such a way as to be supported by the bell.
  - 5. Pipe which has a longitudinal deflection greater than 1/8 inch per foot shall not be used.

6. Pipe which exhibits any signs of ultraviolet deterioration shall not be used.

## **PART 2 - PRODUCTS**

### **2.1 PLASTIC PRESSURE PIPE**

- A. The only sizes of plastic pressure pipe which will be allowed are four (4) inch through twelve (12) inch (inclusive).
- B. All plastic pressure pipe shall be manufactured in accordance with AWWA C900 (DR18) or AWWA C909 (6"-12").
- C. The outside diameter of plastic pressure pipe shall be based upon equivalent outside diameters of ductile iron pipe.
- D. Plastic pressure pipe shall be Class 150, with a dimension ratio of 18 (DR 18).
- E. All plastic pressure pipe shall have a nominal laying length of 20 feet.
  1. Random pipe lengths are not acceptable.

### **2.2 FITTINGS AND COUPLINGS**

- A. All fittings and couplings shall be manufactured in accordance with AWWA C153, C111, C550, C116 and C104.
- B. All fittings and couplings shall have one of the following types of connections:
  1. Flanged joint (not for buried service).
  2. Mechanical joint with mechanical restraints.
- C. All fittings and couplings shall be made of ductile iron, with a minimum working pressure rating of 250 psi.
- D. All transition couplings shall have a fusion bonded epoxy coating and 316 stainless steel fasteners. Reference AWWA C213.



## **2.3 JOINTS**

- A. All joints on plastic pressure pipe shall be push-on, using an integral bell with an elastomeric-gasket.

## **2.4 TRACING WIRE**

- A. Tracing wire shall be a single, 12 gauge, insulated solid copper wire buried directly with the pipe.
- B. Tracing wire will be connected at all piping intersections to form one continuous system. Connections will need to be water tight.
- C. Tracing wire will surface into a test station at all Fire Hydrant locations. Additional locations may be required depending on available Fire Hydrant locations.
- D. Test station shall not be located in traffic or pedestrian areas.
- E. Acceptable test stations are:
  - a. NM-4, C.P. Test Services
  - b. Approved Equal

## **2.5 ACCESSORIES**

- A. Joint restraining devices.
  - 1. Push-on joints shall be restrained with the use of:
    - a. Certainteed C900/RJ Certa-Lok
    - b. Diamond Lok-21
    - c. JM Eagle Loc 900
    - d. Approved Equal
  - 2. Mechanical joints are to be restrained with the use of :
    - a. Megalugs, EBAA Iron Inc.
    - b. Uni-Flange, Ford, Inc..

- c. Stargrip, Star Pipe Products
- d. Field Lock, U.S. Pipe and Tyler Pipe
- e. Approved Equal

### **PART 3 - EXECUTION**

#### **3.1 INSTALLATION**

- A. Reference Section 02713.
- B. PVC pipe shall not be installed when the air temperature or the soil temperature is 32 degrees F or less, unless otherwise approved by the District.

END OF SECTION

## **SECTION 02641**

### **VALVES**

#### **PART 1 - GENERAL**

##### **1.1 DESCRIPTION**

- A. This section addresses valves, valve operators, valve boxes, and valve appurtenances used for water distribution lines.

##### **1.2 PRODUCT DELIVERY, STORAGE, AND HANDLING**

- A. Precautions shall be taken to prevent damage to materials during delivery and storage.
- B. Valves shall be stored off of the ground and away from materials that could contaminate potable water systems.
- C. Precautions shall be taken to keep all joints and internal parts clean.

#### **PART 2 - PRODUCTS**

##### **2.1 GENERAL**

- A. All valves shall open counter-clockwise (left).
  - 1. All nuts and bolts shall be stainless steel.
- B. All buried valves shall have a two (2) inch square operating nut.
  - 1. All operating nuts shall be painted black.
- C. Any valve which will be placed in a vault shall have a valve operator which is specifically approved by the District.

##### **2.2 GATE VALVES**

- A. All gate valves shall be a resilient seat type and manufactured in accordance with AWWA C509.
  - 1. All gate valves shall have a fusion bonded epoxy coated interior and exterior, in accordance with AWWA C550.

2. All gate valves shall have a ductile iron body and 316 SST bolts.
3. Approved manufacturers of gate valves are:
  - a. Mueller
  - b. Waterous
  - c. American AVK
  - d. Approved equal
- B. All gate valves shall be provided with two O-ring type stem seals, in accordance with Section 4.8 of AWWA C509.
- C. The operating nut on all gate valves shall be between four (4) and six (6) feet below finish grade.
  1. If, in order to achieve the operating nut depth noted above, it is necessary to use a riser stem, the riser stem shall be pinned.
- D. All gate valves shall be provided with mechanical joint connections unless otherwise specified.

### **2.3 TAPPING VALVES**

- A. All tapping valves shall be resilient seat type and manufactured in accordance with AWWA C509.
- B. All tapping valves shall be provided with two O-ring type stem seals, in accordance with Section 4.8 of AWWA C509.
- C. All tapping valves shall be equipped with an alignment ring on the flanged side of the valve.

### **2.4 BUTTERFLY VALVES**

- A. Butterfly valves shall be used when the pipe is larger than twelve (12) inches in diameter.
- B. All butterfly valves shall conform to AWWA C504.
  1. All butterfly valves shall have an epoxy coated interior and exterior.
  2. All flanged butterfly valves shall be the short body type.

3. All butterfly valves shall be Class 150B.
4. The operator torque shall be as specified in Appendix A, of AWWA C504.
5. All butterfly valves shall be provided with mechanical joint connections unless otherwise specified.
6. The operator nut shall be located north and/or west of the water line.
7. Approved manufacturers of butterfly valves are:
  - a. Mueller
  - b. Pratt
  - c. Or an approved equal

## **2.5 VALVE BOXES**

### **A. Main Line Valves**

1. Valve boxes shall be an approved 5 1/4 inch shaft, screw-type with the word "WATER" cast into the lid.
2. Valve boxes shall be a heavy duty cast with a total weight of no less than 110 Lbs.
3. All valve box sections and parts shall be uniform to one manufacturer per box installed.
4. Non-threaded paving rings are not accepted by the District.
5. Approved models and manufacturers of valve boxes are:
  - a. 6645, E.J.I.W.
  - b. 6645, Castings Inc.
  - c. 6860 Series, Tyler
  - d. Approved Equal

## **2.6 AIR RELIEF/VACUUM RELIEF VALVES**

- A. Reference the "Typical Air and Vacuum Relief Valve Installation" drawing in the appendix.
- B. Materials and Construction.
  - 1. Air relief and vacuum relief valves shall have an integral type assembly which will function both as an air release and vacuum valve.
  - 2. All air relief and vacuum relief valves shall be rated at a working pressure of 150 psi and a minimum hydrostatic test pressure of 250 psi.
  - 3. The size of air relief and vacuum relief valves shall be as noted on the Construction Drawings.
  - 4. Taps for air relief valves and vacuum relief valves shall be made as indicated on the Construction Drawing, unless otherwise directed by the District.
  - 5. All piping shall be brass.
  - 6. Connections:
    - a. The inlet connection for air relief and vacuum relief valves shall be the diameter as identified on the approved construction drawings conforming to AWWA C800.
    - b. Connections on the outlet side of air relief and vacuum relief valves shall be threaded and shall be protected to minimize entry of debris and dirt into the valve.
  - 7. The working parts and seats of air relief and vacuum relief valves shall be brass, stainless steel, or other non-corroding material.
  - 8. The float of air relief and vacuum relief valves shall be non-corroding material.

## C. Manufacturers

1. Acceptable air release and vacuum relief valves, and their manufacturers are:
  - a. APCO Combination Air Release Valve, by Valve and Primer Corporation.
  - b. A.R.I. Flow Control by A.R.I. Combination Air Valve
  - c. Vent-O-Mat Series RBX, by International Valve Marketing, Inc.

## 2.7 CHECK VALVES

- A. Check Valves will be evaluated on a case-by-case basis.

## PART 3 - EXECUTION

### 3.1 INSTALLATION

- A. Valves and valve boxes shall be examined for cracks, dents, abrasions, and other flaws prior to installation.
  1. Defective valves and valve boxes shall be marked and removed from the site.
- B. Valves
  1. See the “Typical Gate Valve Installation” and the “Typical Butterfly Valve Installation” in the Appendix. Valves shall be located within 18 inches of tees and crosses.
  2. With the exception of tapping valves, flanged valves shall not be buried.
  3. The valve shall be installed in such a manner that the operating nut is perpendicular to the ground surface.
  4. The joined valve shall be supported in place on compacted granular material.
    - a. Reference Section 02221.
- C. Tapping Valves.
  1. Tapping valves shall be installed in accordance with the manufacturer’s recommendations.

2. Tapping valves and sleeves are to be pressure tested to 200 psi, for 10 minutes, with no visible leakage or loss of pressure, prior to proceeding with the wet tap.

D. Valve Boxes.

1. Valve boxes shall be installed on all buried valves.
2. Valve boxes shall be installed so that no stress is transmitted to the valve.
3. Valve operators which are mounted to one side of the valve shall be located to the South or West of the valve.
4. Valve boxes which are to be set over the valve shall be centered, plumb and directly over the operating nut and valve with the top of the box on grade.
  - a. The soil around the valve box shall be carefully compacted around the barrel, to minimize misalignment and the settling of the backfill.
  - b. Other valve box types shall be adjusted as required on the Construction Drawings.

### **3.2 AIR RELIEF/VACUUM RELIEF VALVES**

- A. Air relief and vacuum relief valves shall be installed at high points, and as shown on the Construction Drawings.
- B. Air relief and vacuum relief valves shall be installed in accordance with the "Typical Air and Vacuum Relief Valve Installation" drawing, in the appendix, and as modified on the approved Construction Drawings. Where vents are required in residential areas see "Typical Residential Vent Assembly" in the appendix.

### **3.3 PRESSURE REGULATING VALVES**

- A. Pressure regulating valves shall be evaluated on a case-by-case basis.

### **3.4 OPERATION**

- A. Valves which have been accepted by the District shall be operated by District personnel only, unless otherwise authorized by District representative.

END OF SECTION



## **SECTION 02644**

### **FIRE HYDRANTS**

#### **PART 1 - GENERAL**

##### **1.1 DESCRIPTION**

- A. This section addresses dry-barrel fire hydrants and includes the acceptable products, materials, and construction practices which may be used in the construction and installation of fire hydrants.

##### **1.2 PRODUCT DELIVERY, STORAGE AND HANDLING**

- A. Fire hydrants shall be handled, stored, and protected in such a manner as to prevent damage to materials, coatings, and finishes.
- B. All fittings and joints shall be kept free from dirt, oil and grease.

#### **PART 2 - PRODUCTS**

##### **2.1 GENERAL**

- A. All fire hydrants shall be manufactured in accordance with AWWA C502.
- B. The auxiliary gate valve on the hydrant lateral shall be a six (6) inch resilient seat gate valve with a valve box.
  - 1. If the operating nut on the auxiliary gate valve is more than six (6) feet below finish grade, a riser stem shall be used.
  - 2. Reference Section 02641, Subsections 2.2 and 2.5
- C. The hydrant tee on the main line shall be a swivel tee.
  - 1. Tapping sleeves and valves are acceptable when connecting to an existing water main.
  - 2. Reference Section 02641, Subsection 2.3 and Section 02713, Subsection 2.6
- D. Acceptable fire hydrants and their manufacturers are:
  - 1. Super Centurion, Mueller

2. Waterous Pacer, American Flow Control
3. Approved Equal

## **2.2 MATERIALS AND CONSTRUCTION**

- A. All fire hydrants shall be a dry-barrel type with a break-away traffic flange, designed for a working pressure of 250 psi.
- B. All fire hydrants shall have a minimum main valve opening size of 5-1/4 inches.
- C. Shoe inlets shall be six (6) inches, with mechanical joint fittings.
- D. Fire hydrant laterals shall be buried a minimum of five (5) feet, unless specifically directed by the District.
  1. The maximum bury depth for fire hydrant laterals is (6) feet, unless specifically approved by the District.
- E. The fire hydrant pumper nozzle shall be 4-1/2 inches in diameter with four (4) threads per inch.
  1. Pumper nozzle threads shall be right-handed and National Standard Thread.
- F. The fire hydrant hose nozzles shall be 2-1/2 inch diameter with 7-1/2 threads per inch.
  1. Hose nozzle threads shall be right-handed.
- G. Operating Style
  1. Reference specific fire protection authority as required.
    - a. Poudre Fire Authority
    - b. Loveland Fire Protection District
    - c. Windsor/Severance Fire Protection District
- H. All fire hydrants shall be factory coated to the specific color in accordance with the local Fire Protection Agency.

## **2.3 HYDRANT GRAVEL**

- A. Hydrant gravel shall be a well graded crushed stone or gravel, conforming to ASTM-D448, CDOT #67, as listed below:

SIZE	PERCENT PASSING
1"	100
3/4"	90 - 100
3/8"	20 - 55
#4	0 - 10
#8	0 - 5

**PART 3 - EXECUTION**

**3.1 INSTALLATION**

- A. All fire hydrants shall be installed in accordance with the "Typical Fire Hydrant Installation" drawing in the appendix, and as modified on the approved Construction Drawings.
- B. The Developer's Engineer shall provide offset staking for both vertical and horizontal control.
- C. The joining of laterals, valves, and hydrants shall be handled in the same manner as pipe.
  - 1. The fire hydrant shall be installed vertically plumb with the pumper nozzle facing the direction shown on plans.
  - 2. The fire hydrant shall be set to the elevation staked, to insure that the bury line is at the final grade.
- D. All fire hydrants shall be supported on a minimum of eighteen (18) inches of compacted hydrant gravel.
  - 1. The fire hydrant shall be supported with a concrete block.
- E. A concrete thrust block, with a minimum bearing surface area of four and one half (4-1/2) square feet, shall be placed behind the hydrant shoe.
  - 1. A sheet of eight (8) mil polyethylene film shall be placed between hydrant shoe and concrete thrust block, extending up vertically to finish grade, encapsulating the hydrant barrel.
  - 2. Care shall be taken when placing thrust blocks so that hydrant drain holes remain free of obstructions.

- F. After pouring the thrust block, hydrant gravel shall be placed to a depth of twelve (12) inches above the hydrant shoe.
  - 1. Hydrant drain holes shall remain free of obstructions.
- G. Fire hydrants shall not be placed in concrete sidewalks or pavement.
- H. There shall not be a post, fence, vehicle, growth, trash, storage, or other material or thing, within a three (3) foot radius of the fire hydrant assembly.
  - 1. The ground surrounding the fire hydrant shall slope away from the hydrant at a minimum grade of 2%, toward the street.
- I. After installation of the fire hydrant is complete, the oil/grease reservoir shall be checked to insure that it is full.
  - 1. If it is necessary to fill the reservoir, it shall be filled with the oil/grease which is specified by the hydrant manufacturer.
- J. If a hydrant is raised, no more than one (1) extension section can be used, unless approved by the District.
  - 1. Each fire hydrant extension installed shall be inspected, by the District, prior to re-installation of the fire hydrant body assembly.

### **3.2 OPERATION**

- A. Fire hydrants which have been accepted by the District shall be operated by District personnel only, unless otherwise authorized by District representative

END OF SECTION

## SECTION 02646

### SERVICE LINES, METERS AND APPURTENANCES

#### PART 1 - GENERAL

##### 1.1 DESCRIPTION

- A. This section addresses the materials and installation of corporation stops, service lines, meters, meter setters and meter pits. All material shall be lead free with the manufacturer's identifying mark as lead free.

##### 1.2 PRODUCT DELIVERY, STORAGE AND HANDLING

- A. The product shall be handled, stored, and protected in a manner which will prevent damage to materials, coatings and finishes.
- B. All material shall be kept clean and free from dirt.

##### 1.3 INSTALLATION OF SERVICE TAPS

- A. The Contractor shall not make any taps without prior permission from the District.
- B. Reference the following typical drawings in the appendix and as modified on the approved Construction Drawings for services of less than 3-inches in diameter.
  - 1. "Typical Meter Pit Installation".
  - 2. "Typical Setting for 1-1/2" & 2" Meters".
- C. All taps shall be made with a tapping saddle in accordance with these specifications and the manufacturer's recommendations, unless otherwise approved by the District.
  - 1. A static pressure test of 150 lbs. for ten (10) continuous minutes, with no visible leakage or pressure loss, shall be performed prior to the wet tap on all existing water mains.
- D. Service taps on live mains will be made only under the direct supervision of the District. The Contractor shall coordinate with the District Representative.
- E. The District reserves the right to make taps in lieu of the Contractor and the right to deny permission for any main to be tapped.

F. Tapping equipment shall be of good quality, used for the purpose intended and used in accordance with manufacturer's instructions.

1. Reference Section 01600.

#### **1.4 MAINTENANCE AND CORRECTION**

A. The Contractor shall maintain and repair all service lines, meter pits, and any associated appurtenances which leak, were installed incorrectly, or otherwise prove to be defective, for a period of one (1) year after final completion and acceptance of the work.

#### **1.5 METER PITS AND VAULTS**

A. 3/4-inch and 1-inch meters pits shall be installed by the contractor unless otherwise directed by the District.

1. Meter pits shall be twenty (24) inches in diameter for 3/4-inch meters and twenty four (24) inches in diameter for 1-inch meters, a minimum of forty eight (48) inches in length, and shall be constructed of rigid polyethylene, or an approved equal.

a. Acceptable Meter Pit Barrel Sections are:

1. High Density Polyethylene, Mid States Plastics
2. High Density Polyethylene, DFW
3. 24 inch I.D. – ADS Pipe, 48 inch Long, Cut at Center of Rib with 3 inch Notches
4. Approved Equal

2. Meter pit cover bodies shall be constructed of aluminum, with a cast iron outer lid that shall have a 2" centered hole cut out, and an inner 3" plastic drop lid.

a. The minimum allowable opening for meter pit covers shall be eleven (11) inches diameter.

b. All meter pit covers shall have a 27/32" worm-lock operator with a Standard Waterworks pentagon head.

B. 1 1/2-inch and 2-inch meter vaults shall be installed by the contractor unless otherwise directed by the District.

1. Meter vaults shall be constructed from standard forty eight (48) inch inside diameter precast concrete manhole sections.
  - a. Reference Section 03400.
2. Meter vault covers shall be Castings Aluminum (MH10024AL), with recessed 2 inch hole, manhole cover or an approved equal with a twenty-four (24) inch diameter opening, unless approved by the District.
  - a. All meter vault covers shall have the word "water" cast in the lid.
  - b. Ring section of the cover will be sealed to the top section of the vault using a preformed plastic gasket.

C. 3-inch and larger meter vaults shall be installed by the contractor, unless otherwise directed by the District.

1. Meter vaults shall be constructed from precast concrete box sections designed for H-20 Bridge loading and water tight. Water tight seals shall be installed at all pipe penetrations
  - a. Minimum vault dimensions for different size meters are as follows:

Meter Size	Inside Vault Dimension
3"	6' x 8'
4"	7' x 8'
6"	7' x 11'
Larger	Determined by District

2. Unless it is otherwise specified, meter vault covers shall be an aluminum cover or an approved equal with a twenty four (24) inch diameter opening.
  - a. All meter vault covers shall have the word "water" cast in the lid.
  - b. The ring section of the cover will be sealed to the section of the vault using a preformed plastic gasket.
3. Water tight vaults shall be provided, unless otherwise indicated.
4. Reference Section 2713, "Water Distribution System".

D. Concrete Vaults and Manholes

1. Manhole /vaults shall be constructed at the location and elevation indicated on the approved Construction Drawings, or as directed by the District Engineer to accommodate field conditions.
  - a. The location of manholes/vaults shall be referenced by the Design Engineer, to a minimum of two permanent surface references, and recorded of the Record Drawings.
  - b. Water tight seals shall be installed at all pipe penetrations, three (3) inches and larger.
2. The manhole/vault shall be plumb.
  - a. Pre-cast concrete rings or an approved equal shall be used to bring the ring and cover to grade. The adjustment rings shall be installed in accordance with the manufacturer's recommendations.
  - b. The total height from the top of the manhole/vault to the finish street grade shall not exceed sixteen (16) inches unless otherwise indicated.
  - c. Adjustment rings in paved areas shall be joined using a minimum one (1) inch mortar bed. Adjustment rings in landscape areas can be joined using preformed plastic gasket.
  - d. All joints, lifting holes and other imperfections shall be filled with non-shrink grout to provide a smooth finished appearance.
  - e. Meter pits and vaults are required for all service lines.

## **PART 2 - PRODUCTS**

### **2.1 TAPPING SADDLES**

- A. 3/4 inch, inclusive, through 2-inch, inclusive, tapping saddles shall be constructed of materials in accordance with one of the following descriptions:
  1. Ductile Iron and Asbestos Cement pipe saddles shall have a brass body with double silicon bronze straps.
  2. Poly Vinyl Chloride pipe saddles shall have a brass body with a stainless steel strap.
  3. Thread-O-Lets may be used for weld-on tap saddles for steel pipe;



- a. Nuts, bolts and accessories shall be in accordance with Manufacturer Specifications.
  4. Thread-O-Let saddle outlet threads shall be IP thread with insulated couplings, all other outlet threads on tapping saddles shall be "cc" type only.
- B. 3-inch and larger taps, reference Section 2713, Subsection 2.6.
- C. Acceptable manufacturers of tapping saddles are:
1. Mueller.
  2. Ford.
  3. A.Y. McDonald
  4. Thread-O-Let
  5. There will be no substitutions allowed.

## **2.2 CORPORATION STOPS**

- A. All corporation stops shall conform to AWWA C800.
1. All corporation stops shall be constructed of brass and shall be a ball valve type.
  2. Corporation stop inlet threads for tapping saddles shall be "cc" type only.
  3. All corporation stop outlets shall use compression style connections, with a positive stop.
  4. Corporation stops shall be used for all taps which are two (2) inches and smaller.
- B. Acceptable manufacturers of corporation stops are:
1. Mueller.
  2. Ford.
  3. A. Y. McDonald.
  4. There will be no substitutions allowed.

## **2.3 SERVICE LINES**

- A. Copper pipe shall be used for service lines up to two (2) inches.
- B. All copper services shall conform to the Appendix to AWWA C800.
  - 1. Type K Copper shall be used for copper services.

## **2.4 COUPLINGS**

- A. All couplings shall use compression style connections, with a positive stop.
- B. All couplings shall be constructed of brass.
- C. Acceptable couplings and their manufacturers are:
  - 1. Mueller.
  - 2. Ford
  - 3. A. Y. McDonald
  - 4. There will be no substitutions allowed.

## **2.5 METER SETTERS**

- A. All 3/4-inch and one (1) inch meter setters shall have an angle ball valve with a padlock wing located on the inlet side, vertical inlet and outlet connections, a dual check valve assembly on the outlet, and a seven (7) inch height on 3/4-inch setters, and ten (10) inch height on one (1) inch setters with positive stop compression style lower connections in accordance with the manufacturer's accessory options. The acceptable manufacturers are:
  - 1. Ford.
  - 2. Mueller.
  - 3. A.Y. McDonald
  - 4. There will be no substitutions allowed.

- B. All 1-1/2 inch and two (2) inch meter setters shall have an angle ball valve with a padlock wing, a dual check valve assembly on the outlet, and a built in locking by-pass in accordance with the manufacturer's accessory options. Outlet connections will be horizontal and include positive stop compression connections. The acceptable manufacturers are:
1. Ford.
  2. Mueller.
  3. A.Y. McDonald
  4. There will be no substitutions allowed.
- C. The meter setter distance from the inside flange to flange shall be:
1.  $\frac{3}{4}$ " meter = 7  $\frac{1}{2}$ " opening distance
  2. 1" meter = 10  $\frac{3}{4}$ " opening distance
  3. 1  $\frac{1}{2}$ " meter = 13" opening distance
  4. 2" meter = 17" opening distance

### **PART 3 - EXECUTION**

#### **3.1 GENERAL**

- A. The Contractor shall make all taps and install the service line to the permanent facilities prior to disinfection and pressure testing of the water main.
- B. The Contractor shall adjust meter pits to the horizontal location and to the final grade as determined by the grade stake.
1. Reference Subsections 3.4 and 3.5 in this section.
  2. Grade stakes shall not be disturbed prior to inspection of the service by the District.
- E. The Contractor shall mark the location of the water service with a scored "W", four (4) inches high, into the face of the curb and gutter.

### **3.2 SERVICE LINE TAPS**

- A. Taps shall not be made within two (2) feet of any joint or fitting.
- B. Taps shall be separated by at least two (2) feet (measured along the pipe length), even when taps are made on opposite sides of pipe.
- C. Taps which are made on the same side of the pipe and within ten 10 feet of each other (measured along the pipe length), shall be staggered fifteen degrees.
- D. Ductile Iron Pipe Taps
  - 1. Corporation stops shall be installed by means of a tapping saddle unless otherwise indicated on the approved Construction Drawings or as directed by the District representative.
- E. PVC Pipe Taps.
  - 1. Corporation stops shall be installed by means of a tapping saddle unless otherwise indicated on the approved Construction Drawings or as directed by the District representative.

### **3.3 SERVICE LINES**

- A. All service lines shall be a minimum of five (5) feet, and a maximum of six (6) feet, below the final grade.
- B. There will be a maximum of one coupling per service, between the main and the meter pit, or meter vault assembly.
  - 1. Service lines (3/4-in. through 2-in.) shall be uniform in size from the corporation stop to five (5) feet past the meter pit.
- C. When backfilling the service trench, sand shall be used at a minimum of four (4) inches under and six (6) inches above any given location of the service line.
  - 1. Sand shall conform to ASTM C 33.
  - 2. Reference chart on page 02221-5, Subsection 2.2, Part B-1
- D. Service trenches shall be subject to compaction specifications.
  - 1. Reference Section 02221, Subsection 3.6 and 3.7.

### **3.4 METER PITS AND VAULTS**

- A. Exterior meter settings shall be installed according to the manufacturers recommendations, and in accordance with the "Typical Meter Pit Installation" or the "Typical Setting for 1-1/2" & 2" Meters" drawings in the appendix.
- B. Meter pits and vaults shall not be installed in any street, alley, parking area, driveway, or sidewalk, unless otherwise authorized by the District.
- C. There will be no major landscaping (trees, shrubs, boulders, etc.) or structure (retaining wall, etc.) within a ten (10) foot radius of the meter pit or vault structure.
- D. The ground surrounding meter pits and vaults shall slope away from the lid at a minimum grade of two (2) percent, toward the street.
- E. There will be no plumbing connections inside the meter pit or vault.
- F. All tees, connections, and couplings shall be a minimum of five (5) feet from the meter box, pit, or vault wall on the downstream side.
- G. Meter pit and vault covers shall be adjusted to one (1) inch above final grade.
- H. Concrete meter vaults.
  - 1. Reference Section 2713, Subsection 2.7, and Section 3400, Subsection 2.1

### **3.6 INSPECTION**

- A. The Contractor shall insure that the corporation stop and any couplings remain exposed until after the inspection and the approval for backfill is given by the District.
- B. All tap and service inspections shall be scheduled with the District.
  - 1. A minimum of 48 hours notice is required on all tap and service inspections.
- C. The water shall be turned on by the District, only after the service line and meter setting is approved.

END OF SECTION

## **SECTION 02713**

### **WATER DISTRIBUTION SYSTEM**

#### **PART 1 - GENERAL**

##### **1.1 DESCRIPTION**

- A. This section addresses the acceptable products, materials, and construction practices which may be used in the installation of water distribution mains.

##### **1.2 QUALITY ASSURANCE**

- A. Water system installations shall conform to the regulations of the Colorado Department of Health, and the Water Quality Control Commission.
- B. Construction staking.
  - 1. Reference Section 02221, Subsection 1.2.
- C. Horizontal alignment shall not deviate by more than six (6) inches.
- D. Vertical alignment shall not deviate by more than three (3) inches, as measured from the pipe invert.
- E. The minimum effective area of thrust blocks shall be as specified in "Typical Concrete Thrust Blocks" drawing in the appendix.

##### **1.3 PRODUCT DELIVERY, STORAGE AND HANDLING**

- A. Reference Sections 02615, 02622, 02641, 02644, 02646

##### **1.4 JOB CONDITIONS**

- A. Foreign material (debris, tools, clothing, or other material), including trench water, shall not be permitted in the pipe.
- B. In order to prevent water, debris, and animals from entering the pipe, the open ends of the pipe shall have a watertight plug installed when pipe laying is not in progress.
- C. Effective measures shall be used to prevent uplifting or floating of the pipeline prior to completion of the backfilling operations. Dewatering methods and procedures shall be the responsibility of the installation contractor.

- D. Pipe shall not be installed under the following conditions:
  - 1. When the trench contains water.
  - 2. When weather conditions are unsuitable.
    - a. Temperature is less than 10° Fahrenheit. District approval is required when the temperature is 32° Fahrenheit or less. Contractor shall install the pipe in accordance with manufacturer's recommendations.
  - 3. When the trench bottom is unstable.
- E. Pipe and appurtenances shall be protected against dropping and damage.
  - 1. Pipe and appurtenances shall not be used if they are damaged.

## **PART 2 - PRODUCTS**

### **2.1 PIPE**

- A. The same type of pipe material shall be used for each size pipe.
  - 1. Pipe material shall not be interchanged, except where another type of pipe material is specifically indicated.

### **2.2 VALVES**

- A. Reference Section 02641.

### **2.3 FIRE HYDRANTS**

- A. Reference Section 02644.

### **2.4 BLOW-OFFS**

- A. All permanent blow-offs shall be a Mueller Super Centurion 250 with two (2) 2.5" NST thread nozzles a 5-½ inch MVO, with a six (6) inch mechanical joint shoe, or as approved on the Construction Drawings
  - 1. Blow-off operation and color shall match the specifications of the jurisdictional fire agency.

## **2.5 SERVICE LINES, METERS, APPURTENANCES**

- A. Reference Section 02646.

## **2.6 TAPPING SLEEVES**

- A. Tapping sleeves and valves are required for connections to existing water mains unless otherwise indicated on the Construction Drawings, or approved by the District.
- B. Tapping sleeves for PVC and Ductile Iron pipe shall be a stainless steel construction with a stainless steel or ductile iron flange, Approved manufacturers are:
  - 1. ROMAC
  - 2. Ford
  - 3. JCM
  - 4. Or Approved Equal
- C. Tapping sleeves for steel pipe shall be a weld-on type, approved by the District.

## **2.7 CONCRETE VAULTS AND MANHOLES**

- A. Mortar.
  - 1. Mortar shall be Sand-Cement grout using the following ratio:
    - a. One (1) part Portland cement; conforming to ASTM C150, Type I/II.
    - b. Two (2) parts sand; conforming to ASTM C144.
    - c. One half (1/2) part hydrated lime; conforming to ASTM C207, Type S.
- B. Grout
  - 1. Grout shall be one of the following:
    - a. Pre-mixed non-metallic grout; acceptable types and manufacturers listed below:
      - i. Master Builders; "Embeco Mortar".
      - ii. Sonneborn; "Ferrolith G-D.S. Redi-Mixed".



- iii. Approved equal.
- b. Job-mixed grout shall use the following ratio:
  - i. One (1) part Portland Cement; conforming to ASTM C207, Type I/II.
  - ii. One (1) part sand; conforming to ASTM C144.
  - iii. One (1) part shrinkage correcting aggregate. Acceptable types and manufacturers are:
    - Master Builders; "Embeco Aggregate".
    - Sonneborn; "Ferrolith G-D.S."
    - Approved equal.

C. Steps

- 1. All steps shall be made of the following materials:
  - a. Copolymer polypropylene plastic conforming to ASTM C478 and ASTM C497.
  - b. Acceptable steps and their manufacturers are:
    - i. Neenah; R-1982-W.
    - ii. M. A. Industries; PS-2-PFS.
  - c. All steps shall be spaced twelve (12) inches apart (O.C.).
  - d. The maximum distance from the cover to the top most step shall be twenty four (24) inches.
  - e. The maximum distance from the bench of the manhole to the lowest step shall be eighteen (18) inches.

D. Pipe Penetration seals.

- 1. Approved seals and their manufacturers:
  - a. LINK-SEAL; Thunderline Corp.

- b. Approved equal.

### **PART 3 - EXECUTION**

#### **3.1 INSPECTION**

- A. Pipe barrel and fittings shall be free of dirt or other foreign objects prior to installation.
- B. Pipe and fittings shall be inspected for cracks, dents, abrasions or other flaws prior to installation.
- C. Pipe and fittings with damaged linings or coatings shall be rejected.
  - 1. Defective pipe shall be marked and remain on the site until removal is approved by the District.

#### **3.2 PREPARATION**

- A. Trenching, backfilling, and compacting.
  - 1. Reference Section 02221.
- B. Connections.
  - 1. The location and elevation of the existing utilities shall be verified prior to construction.
- D. Joints
  - 1. Dirt, oil, grit, and other foreign matter shall be removed from the inside of the bell and outside of the spigot.
  - 2. A thin film of lubricant shall be applied to the inside of the gasket and the spigot end of the pipe, per the manufacturer's recommendations.
  - 3. The lubricated joint shall be kept clean until joined
  - 4. The pipe shall have a depth mark prior to the assembly to insure that the spigot end is inserted to the proper depth of the bell end joint.
  - 5. Stabbing the pipe shall not be allowed.
  - 6. Previously completed joints shall not be disturbed during the jointing operation.

7. After the initial acceptance of the water main, the Contractor shall be responsible for the repair of any leak, resulting from improper workmanship or materials, which are discovered within the one (1) year warranty period.

### **3.3 PIPE INSTALLATION**

- A. All pipe shall be installed with the bells pointing in the direction that the work is progressing.
- B. The Contractor shall employ effective measures to prevent the separation of joints during bedding and backfilling operations.
  1. Bedding material shall not be dropped onto unsupported pipe, which has been set to alignment and grade.
  2. Pipe shall be laid and maintained at required lines and grades as specified in the approved Construction Drawings.
- C. Ductile iron pipe shall be installed with a polyethylene encasement.
- D. Tracing wire shall be installed with all water mains.
  1. Reference Section 02615, Subsection 2.4.
- E. The pipe shall be secured in place with the specified bedding consolidated under and around the pipe.
- F. The pipeline shall be installed so that a uniform positive or negative grade is maintained between the designed high and low points.
- G. The minimum depth of cover shall be five (5) feet from the finished grade to the top of the pipe, except as otherwise indicated on the Construction Drawings.
- H. The maximum depth of cover shall be six (6) feet from the finished grade to the top of the pipe, except as otherwise indicated on the Construction Drawings.
- I. Concrete encasements shall be provided where indicated on the Construction Drawings only. Written District approval is required for all other cases.
  1. Cast-in-Place Concrete.
    - a. Reference Section 03300.

2. At any location where a water main crosses a sewer line, and the sewer is above the water main, or the vertical distance between the two mains is less than 18-inches, the crossing shall be constructed by the following method:
  - a. One length of pipe, with a laying length of 18-feet, or greater, shall be installed.
    - i. The pipe shall be centered on the crossing such that no pipe joints are within ten (10) feet.
3. Suitable backfill or other structural protection shall be provided to prevent settling or failure of the higher pipe.

### **3.4 CONCRETE THRUST RESTRAINT (Requires District Approval)**

- A. Concrete anchorage and blocking. District approval is required for the use or installation of concrete thrust blocks.
  1. Concrete anchorage and blocking is required for fire hydrants and allowed by specific approval only. Signed construction drawing does not constitute approval for use in other location.
  2. Reference the "Typical Concrete Thrust Blocks" drawing in the appendix.
  3. The minimum size of thrust blocks shall be determined from the table in the "Typical Concrete Thrust Blocks" drawing in the appendix.
  4. The concrete thrust block bearing surface shall be excavated into undisturbed soil.
    - a. All loose soil shall be disposed of, and the location where the thrust block is to be poured shall be carefully shaped to provide a uniform bearing surface of the required size.
    - b. The concrete thrust block bottom shall be flat, and sides shall be vertical.
    - c. If soil is to be disturbed, making a concrete thrust block unusable, alternate restraining systems must be approved by the District prior to pipeline installation.
  5. The concrete thrust block shall be formed to provide access to fittings and hydrants.
  6. Concrete shall be separated from fittings and hydrants by an 8 mil polyethylene film.

- a. Concrete shall not be poured directly on or over fittings, nuts, bolts, flanges, etc.
- 7. The District shall be notified 24 hours before concrete is placed.

**B. Restraining Devices**

- 1. Reference Section 02615, Subsection 2.
- 2. The Design Engineer shall determine the length of pipe to be restrained for each situation where mechanical restraint systems are installed.
- 3. All auxiliary fire hydrant / (blow-off) valves shall be restrained to prevent the movement of the valve during hydrant / (blow-off) removal or maintenance.

**3.5 INSTALLATION OF PIPELINE APPURTENANCES**

- A. Valves, hydrants, taps, and other appurtenances to the water distribution lines shall be installed at the locations shown on the Construction Drawings, or as approved by the District to accommodate field conditions.
  - 1. Measurements of the actual location of appurtenances shall be made prior to backfilling for recording in the Project Record Drawings.
- B. Dead-end water lines shall have a fire hydrant at the end of the waterline to facilitate the discharge of air and water from the waterline.
  - 1. Dead-end water lines that will be extended in the future shall have a valve which controls that section of waterline left in the on position.
    - a. If the waterline is to be extended in the future, the fire hydrant may be installed temporarily, until the extension occurs.
- D. Temporary blow-offs which are installed by the Contractor during construction shall be abandoned at the main prior to acceptance of the waterline.
- E. Install fiberglass marker posts at all line valves, air valves, and at intervals not to exceed 1,000 feet as determined by the District.

### **3.6 FIRE LINES**

- A. The District owns the fire line valve on the District's water main and the owner is responsible for all facilities beyond the valve.
- B. The fire line Back-Flow-Prevention device (BFPD) with flow detection must be located within a maximum 300 feet of the District water main. The BFPD is to be located on the fire line riser at the piping entrance into the building or structure.
- C. Fire lines shall be installed at the location shown on the District approved construction drawings, or as directed by the District.
- D. All materials and testing shall, at a minimum, conform to District specifications or as directed by the jurisdiction having authority.
- E. District representative must be on-site to witness BFPD testing on new fire lines.

### **3.7 CROSS-CONNECTION CONTROL**

- A. Connections to District facilities shall conform to the latest edition of the Colorado Cross-Connection Control manual. Only those backflow prevention assemblies described in Foundation for Cross-Connection Control and Hydraulic Research of the University of Southern California (FCCC&HR) most current "List of Approved Backflow Prevention Assemblies" and, in the case of single-family residences, those assemblies bearing the approval of the American Society of Sanitary Engineers (ASSE), are approved by the Backflow coordinator for use as hereinafter set forth in these Rules and Regulations. Only such approved backflow prevention assemblies shall be used, and no substitutions will be allowed.
  - 1. Reference: Colorado Department of Public Health and Environment/ Water Quality Control Division.
  - 2. Reference: Foundation for Cross-Connection Control and Hydraulic Research of the University of Southern California (FCCC&HR).
  - 3. Reference: American Society of Sanitary Engineers (ASSE).
  - 4. Reference: Fort Collins – Loveland Water District Back-Flow-Prevention-Device Manual.

### **3.8 PROTECTION OF METAL SURFACES**

- A. If the supplied material has not been factory coated, or the coating has been damaged by installation, the material shall be protected by one of the following methods:
1. Two coats of coal tar epoxy paint shall be applied to ferrous metal rods, rebar, clamps, bolts, nuts and other accessories which are subject to submergence or contact with earth or fill material, and are not encased in concrete.
    - a. The first coat of coal tar epoxy paint shall be applied to a dry, clean surface.
    - b. The first coat of coal tar epoxy paint shall be allowed to dry before the second coat is applied.
  2. Ferrous metal rods, rebar, clamps, bolts, nuts and other accessories which are subject to submergence or contact with earth or fill material, and not encased in concrete shall be protected with coal tar epoxy paint or a rubberized spray-on undercoating, and wrapped by a minimum 8 mil polyethylene film.
    - a. The rubberized spray-on undercoating shall be either:
      - i. NAPA: Mac's Rubberized Undercoating
      - ii. Tite-Seal Rubberized Undercoating
      - iii. Or approved equal.

END OF SECTION

## **SECTION 03300**

### **CAST-IN-PLACE CONCRETE**

#### **PART 1 - GENERAL**

##### **1.1 DESCRIPTION**

- A. This section covers cast-in-place concrete for thrust restraints, encasement, and cut-off walls, including forms, reinforcing steel, finishing and curing, and other appurtenant work.

#### **PART 2 - PRODUCTS**

##### **2.1 CEMENT**

- A. All cement shall be Portland Cement.
  - 1. Portland Cement shall conform to ASTM C150.
  - 2. Portland Cement shall be Type I/II or Type V.
    - a. 12, 24, or 48 hour concrete mixtures may be used with prior approval of the District.
    - b. Acceptable manufacturer of early strength cement is Quix Strength, or an approved equal.

##### **2.2 AGGREGATES**

- A. All fine and course aggregate shall conform to ASTM C33.

##### **2.3 WATER**

- A. All water shall be free from objectionable quantities of silt, organic matter, alkali, salts, and other impurities or conform to ASTM C94.

##### **2.4 ADMIXTURES**

- A. An air-entraining agent shall be used in all concrete.
  - 1. All air-entraining agents shall conform to ASTM C260.



- B. A water-reducing admixture may be used.
  - 1. A water-reducing admixture shall conform to ASTM C494, for Type A or Type D chemical admixture.
  - 2. The water-reducing admixture shall not contain any calcium chloride.
  - 3. The water-reducing admixture shall be compatible with the cement being used.
- C. Accelerators
  - 1. Accelerators shall conform to ASTM C494 and ACI 306.
    - a. If calcium chloride is used as an accelerator, the amount used should not exceed 2%, by weight, of the cementitious material.
    - b. Calcium chloride shall be in solution prior to adding it to the batch process.
- D. Fly-Ash
  - 1. When fly-ash is used in concrete, the cement replacement shall not exceed 20%.
    - a. Class C or Class F fly-ash shall conform to ASTM C618.
- E. Any admixtures except air entraining agents and accelerators must be approved by the District.

## **2.5 CONCRETE REINFORCEMENT**

- A. All deformed reinforcing bars shall conform to ASTM A615 or ASTM A617.
  - 1. All bars shall be either Grade 40 or 60.
- B. All welded steel wire fabric shall conform to ASTM A185.

## **PART 3 - CONCRETE**

### **3.1 GENERAL**

- A. Concrete shall have a minimum of 6 sacks per cubic yard, and shall be allowed to develop a minimum compressive strength of 3,000 psi at 28 days.
- B. Concrete shall have a maximum allowable water/cement ratio of 0.50, by weight.

1. The water cement ratio may be increased to 0.56, by weight, if a water-reducing agent is used.

- a. Reference subsection 2.4 in this section.

### **3.2 PLACING**

- A. Concrete shall not be placed unless the air temperature adjacent to the concrete placement is 30 degrees Fahrenheit, and rising.

1. The temperature of the mix shall not be less than 50 degrees Fahrenheit, nor more than 90 degrees Fahrenheit at the time of the placement.
  2. If heated water and/or an accelerator is used, the above temperature restrictions may be waived.

- a. Water shall not be heated to a temperature exceeding 150 degrees Fahrenheit.

- B. Concrete shall be placed when the temperature of the plastic concrete can be maintained at 90 degrees Fahrenheit, or lower, unless approved by the District.

1. To facilitate the placement of concrete in hot weather, the aggregate of the water may be cooled.

### **3.3 FINISHING**

- A. Vault bases shall be trowel finished.

### **3.4 CURING**

- A. Finished concrete shall be cured by protecting it against moisture loss, rapid temperature change, and from rain, flowing water and mechanical damage for a minimum of 72-hours after placement.

1. Concrete shall be maintained at a minimum temperature of 50 degrees Fahrenheit during the curing period.
  2. The Contractor is responsible for protecting the concrete from traffic and the elements.

END OF SECTION

## **SECTION 03400**

### **PRECAST CONCRETE**

#### **PART 1 - GENERAL**

##### **1.1 DESCRIPTION**

- A. This section addresses precast concrete products.
- B. Reference Sections 02713, Subsection 2.7.

##### **1.2 PRODUCT DELIVERY, STORAGE AND HANDLING**

- A. All precast concrete parts shall be handled, stored, and protected in a manner which will prevent damage to materials.

#### **PART 2 - PRODUCTS**

##### **2.1 PRECAST CONCRETE PRODUCTS**

- A. Barrels, boxes, and flat slab tops of vaults and meter pits shall conform to and be designated as ASTM C478, and shall be made with Type I/II cement.
  - 1. Reference Section 2713, "Water Distribution System", and subsection 2.7.
  - 2. Flat, slab tops will be used on all vaults and meter vaults unless otherwise approved, in writing, by the District,
- B. Concrete and Reinforcing Materials.
  - 1. Reference Section 03300, part 3 and Subsection 2.5.
  - 2. Reference ASTM C478.

END OF SECTION

## Appendix

Typical Trench and Bedding

Typical Pipe Casing

Typical Gate Valve Installation

Typical Butterfly Valve Installation

Typical Air & Vacuum Relief Valve Installation

Typical Residential Vent Assembly

Typical Fire Hydrant Installation

Typical Meter Pit Installation

Typical Double Meter Pit Installation

Typical Installation for 1½" & 2" Meters

Typical Utility Service Location

Typical Concrete Thrust Blocks

Typical Sample Station

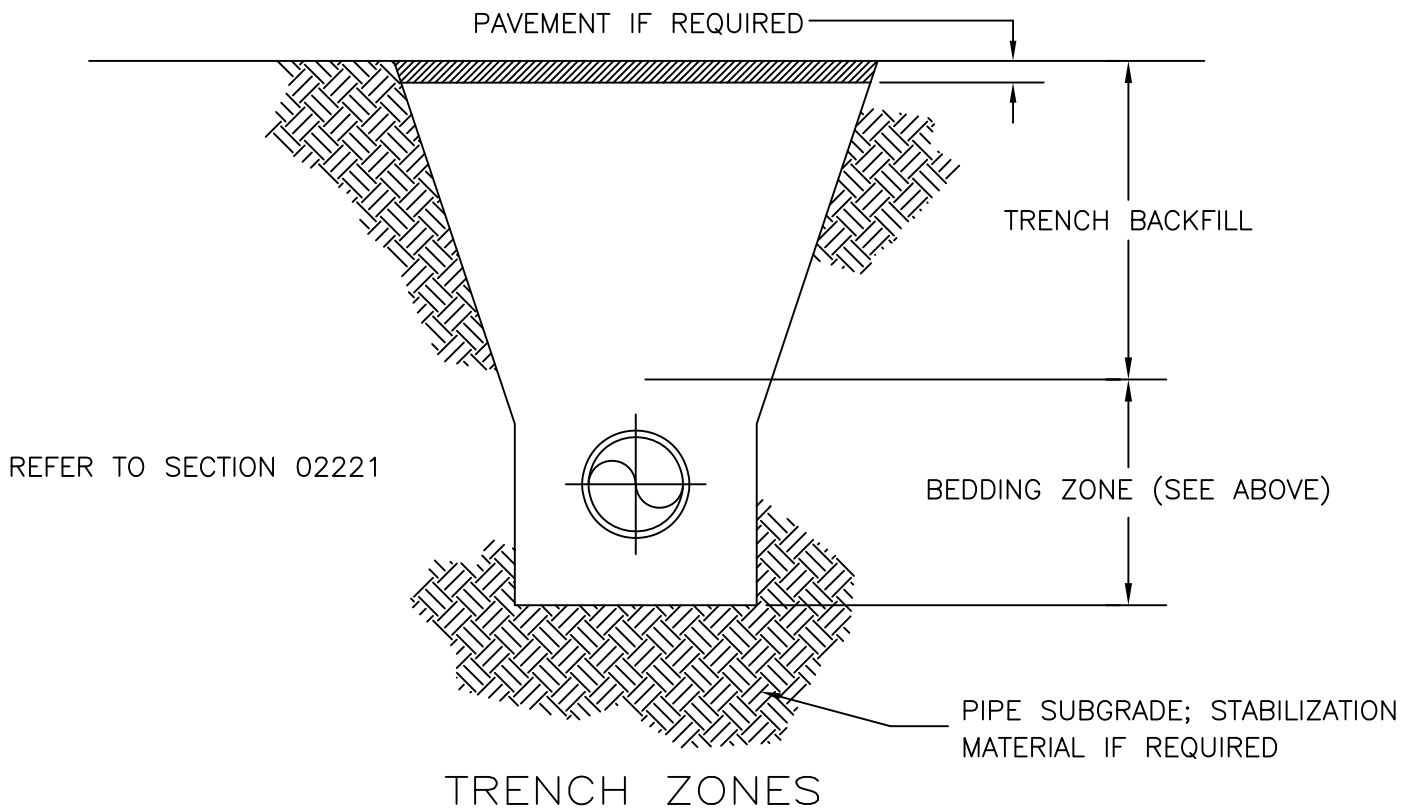
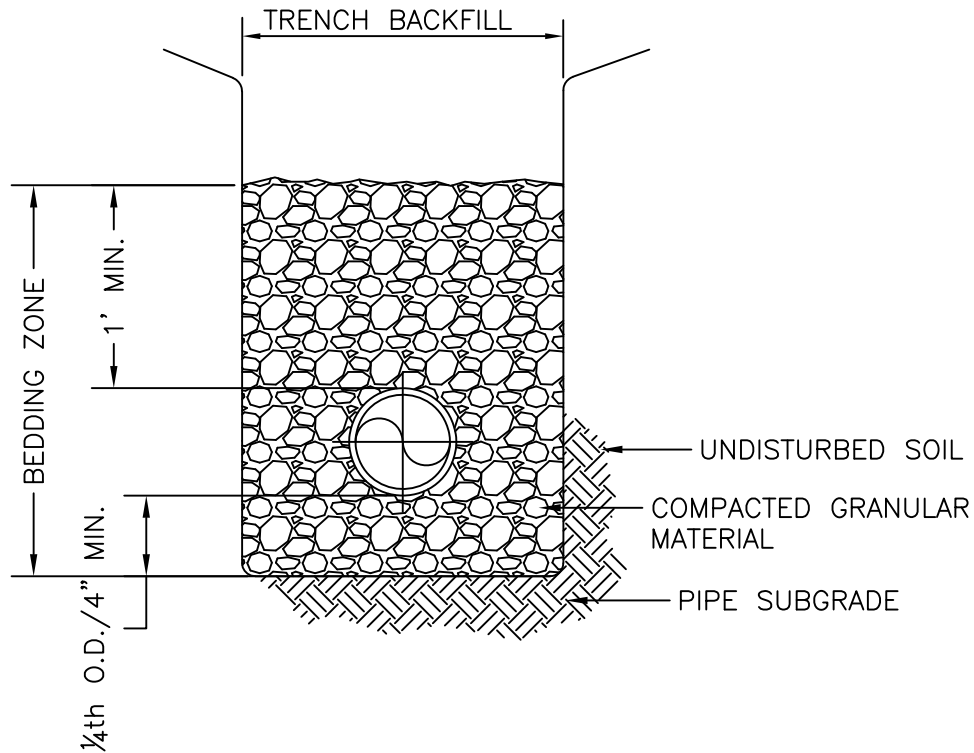

## TRENCH AND BEDDING TYPICAL



FORT COLLINS - LOVELAND WATER DISTRICT  
 Office (970) 226-3104 Fax (970) 226-0186

APPROVED:

DATE:

6-18-2010

SCALE: NTS

ANODE LEADS	BLACK
PIPELINE TEST WIRES	RED FOR STEEL BLUE FOR DI
CASINGS	ORANGE
REF ELECTRODE	YELLOW
TRACER WIRE	WHITE

1/2" MAXIMUM

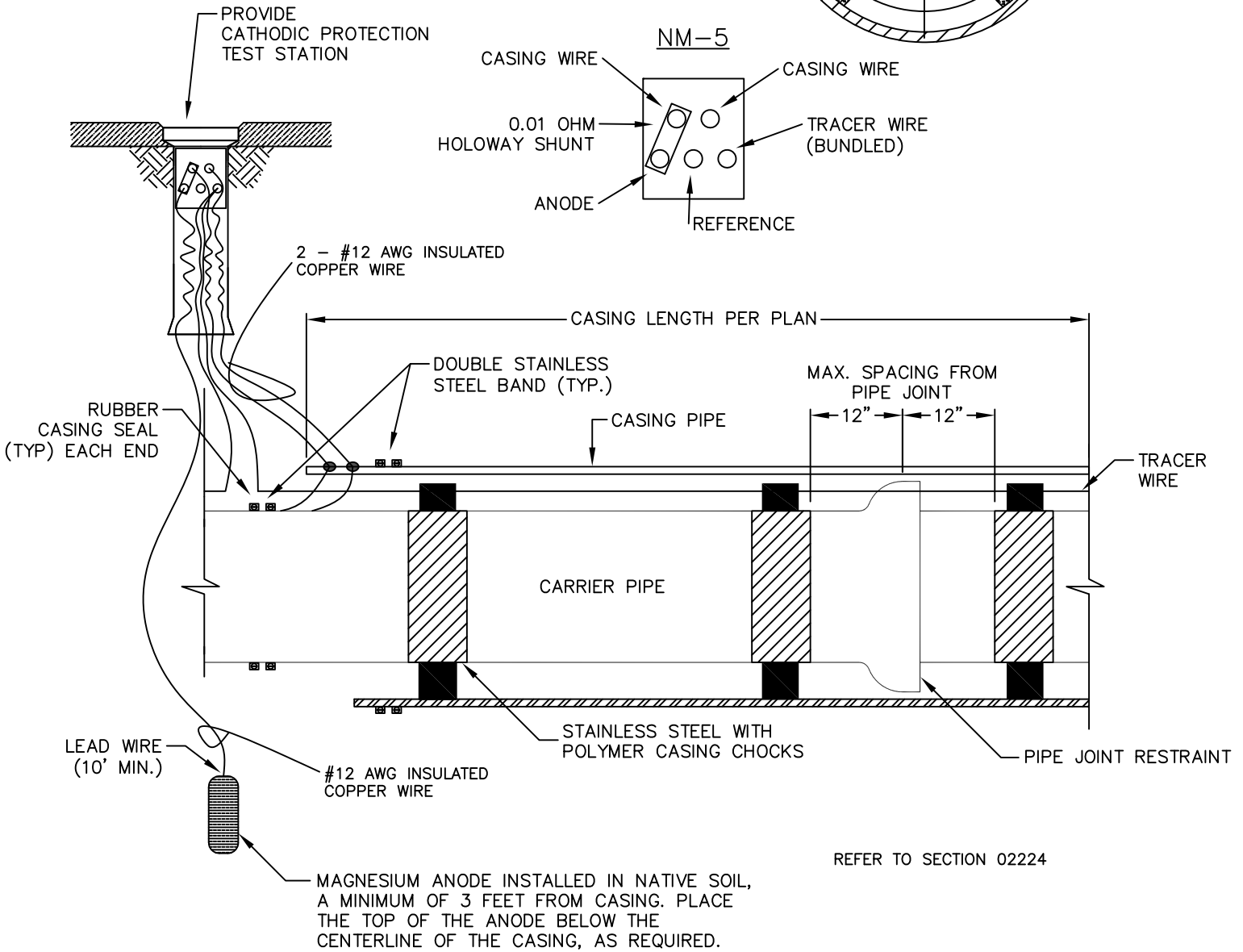
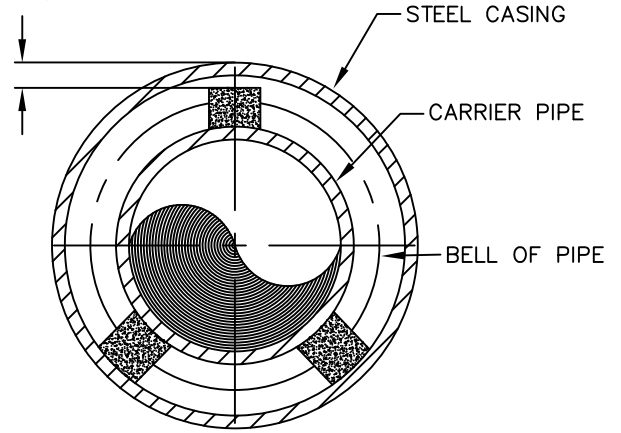

REFER TO SECTION 02224

**NOTES:**

1. EACH BARREL SECTION OF PIPE WITHIN THE CASING SHALL HAVE A MINIMUM OF (3) CASING CHOCKS. THE MIDDLE CHOCK SHALL BE CENTERED BETWEEN EACH PIPE JOINT.

## TYPICAL PIPE CASING



FORT COLLINS - LOVELAND WATER DISTRICT  
Office (970) 226-3104 Fax (970) 226-0186

APPROVED:

DATE:

2-22-2012

SCALE: NTS

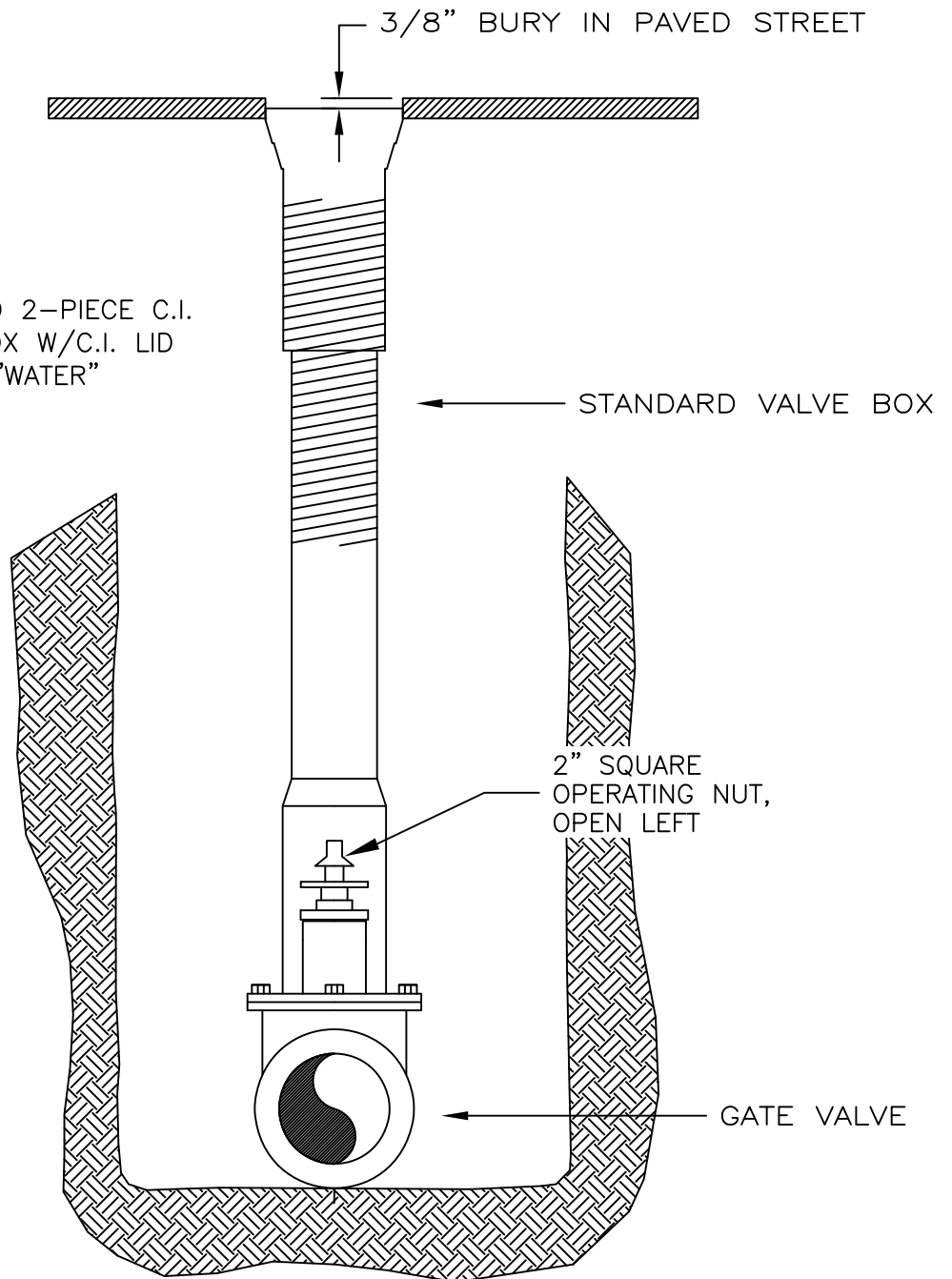

STANDARD 2-PIECE C.I.  
VALVE BOX W/C.I. LID  
MARKED "WATER"

← STANDARD VALVE BOX

2" SQUARE  
OPERATING NUT,  
OPEN LEFT

REFER TO SECTION 02641

← GATE VALVE

NOTE:  
VALVE BOX SHALL BE CENTERED AND PLUMB OVER THE OPERATING NUT.

## TYPICAL GATE VALVE INSTALLATION



FORT COLLINS — LOVELAND WATER DISTRICT  
Office (970) 226-3104 Fax (970) 226-0186

APPROVED:

DATE:

6-18-2010

SCALE: NTS

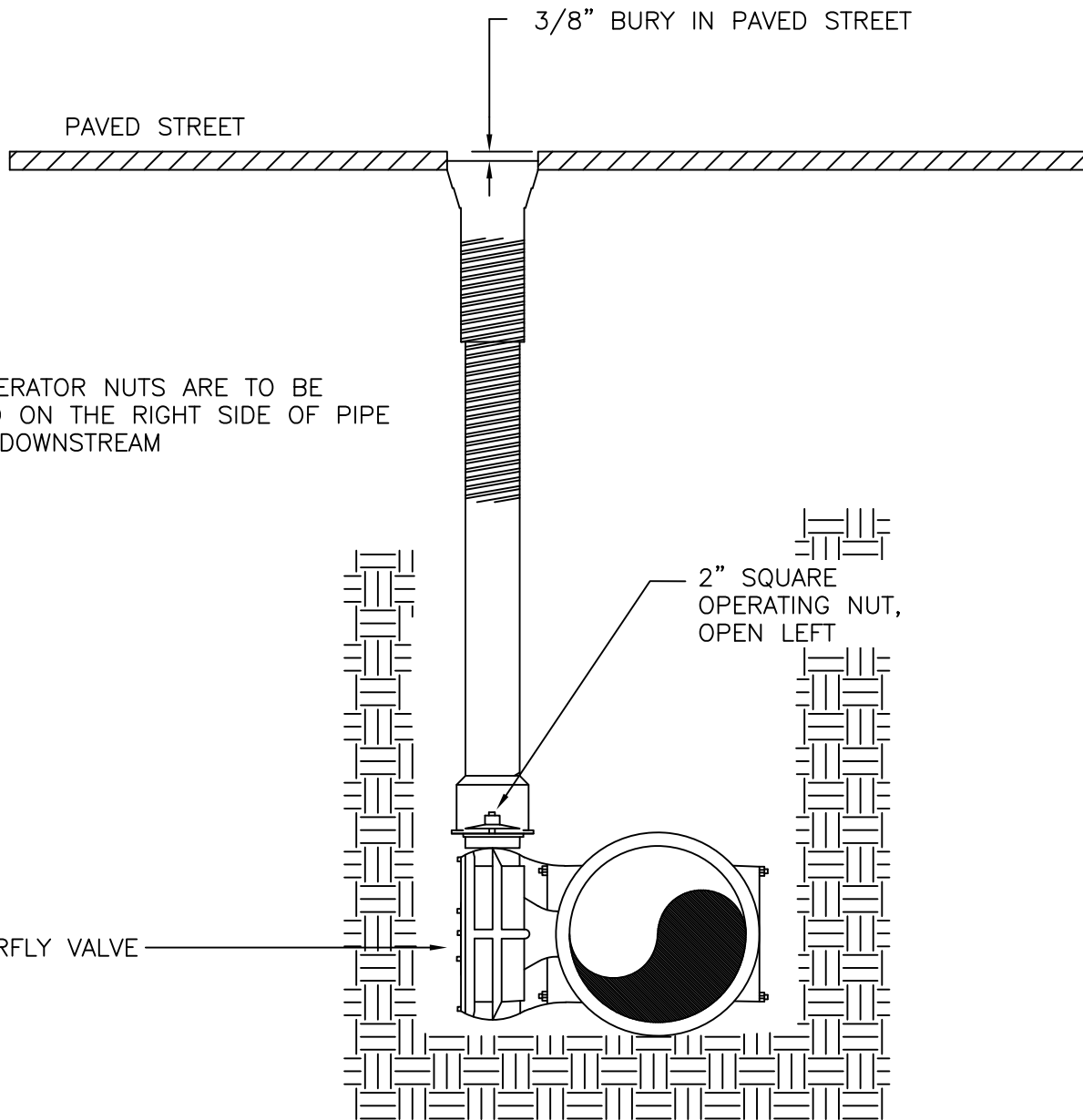

THE OPERATOR NUTS ARE TO BE LOCATED ON THE RIGHT SIDE OF PIPE FACING DOWNSTREAM

NOTE:  
VALVE BOX SHALL BE CENTERED AND PLUMB OVER THE OPERATIONAL NUT.

REFER TO SECTION 02641

## TYPICAL BUTTERFLY VALVE INSTALLATION



FORT COLLINS – LOVELAND WATER DISTRICT  
Office (970) 226-3104 Fax (970) 226-0186

APPROVED:

DATE:

6-18-2010

SCALE: NTS



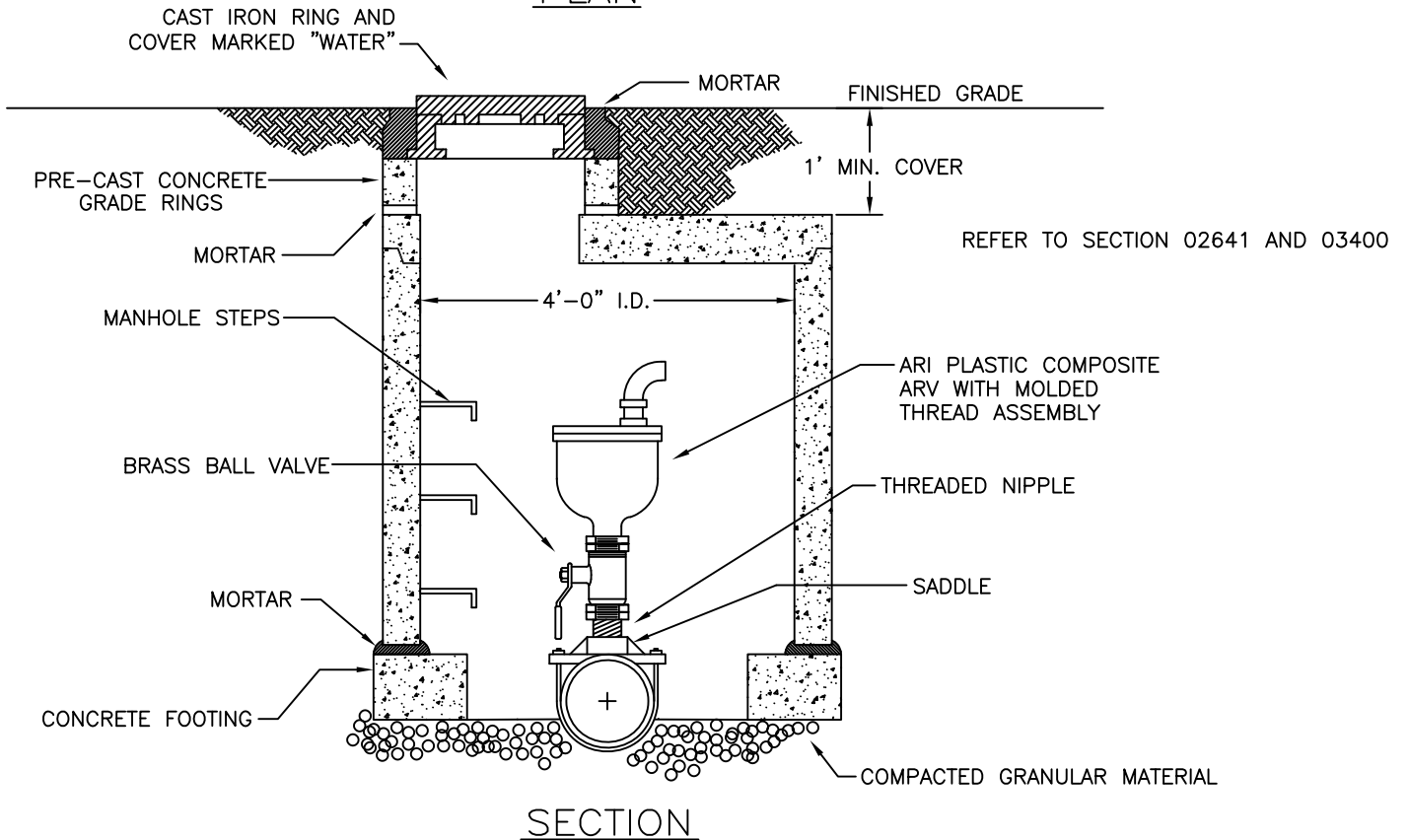
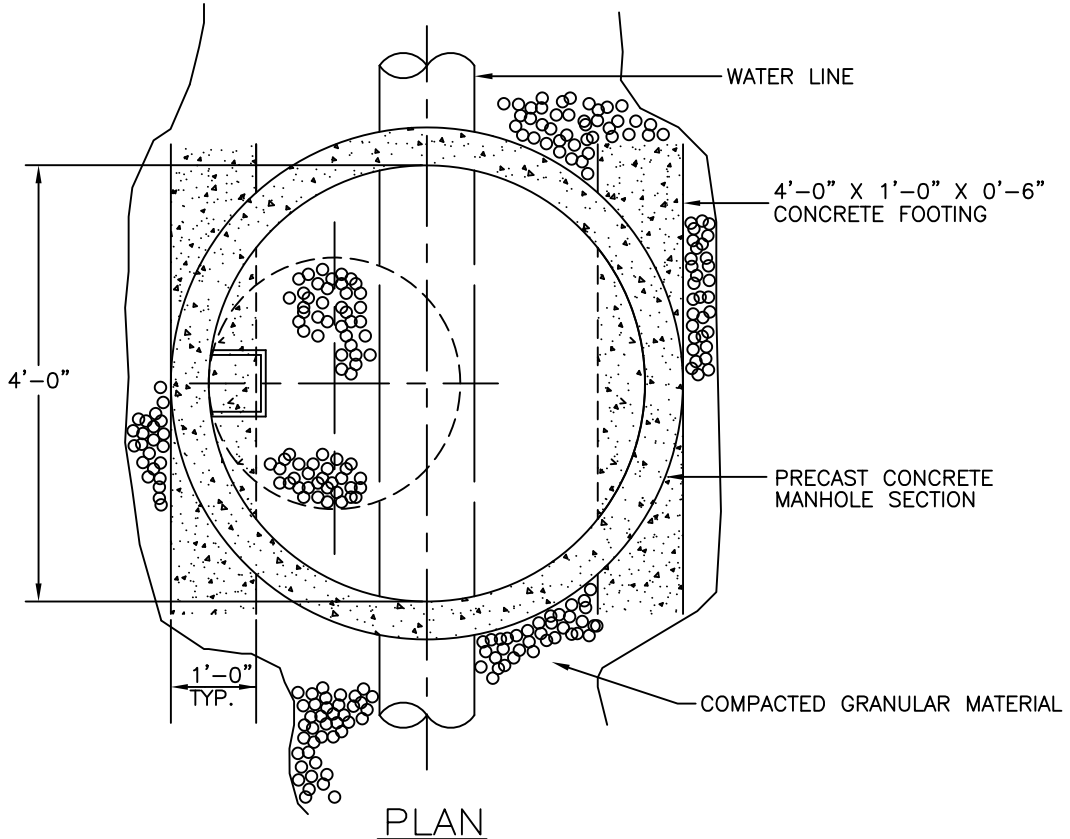

# TYPICAL AIR & VACUUM RELIEF VALVE INSTALLATION



FORT COLLINS - LOVELAND WATER DISTRICT  
 Office (970) 226-3104 Fax (970) 226-0186

APPROVED:  
 DATE: 04-23-2019

SCALE: NTS

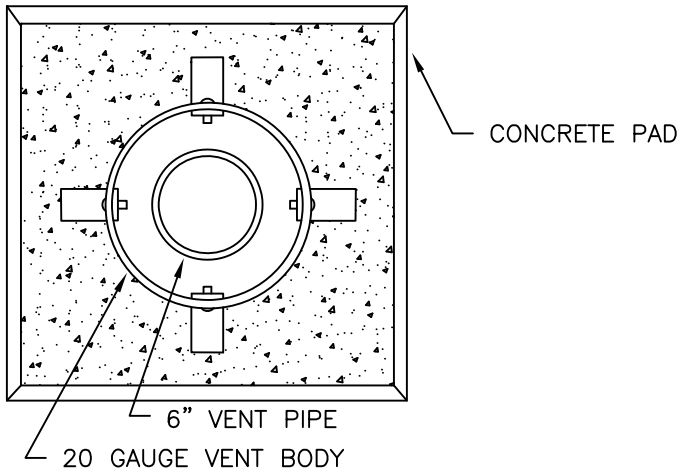

BASE DETAIL  
N.T.S.

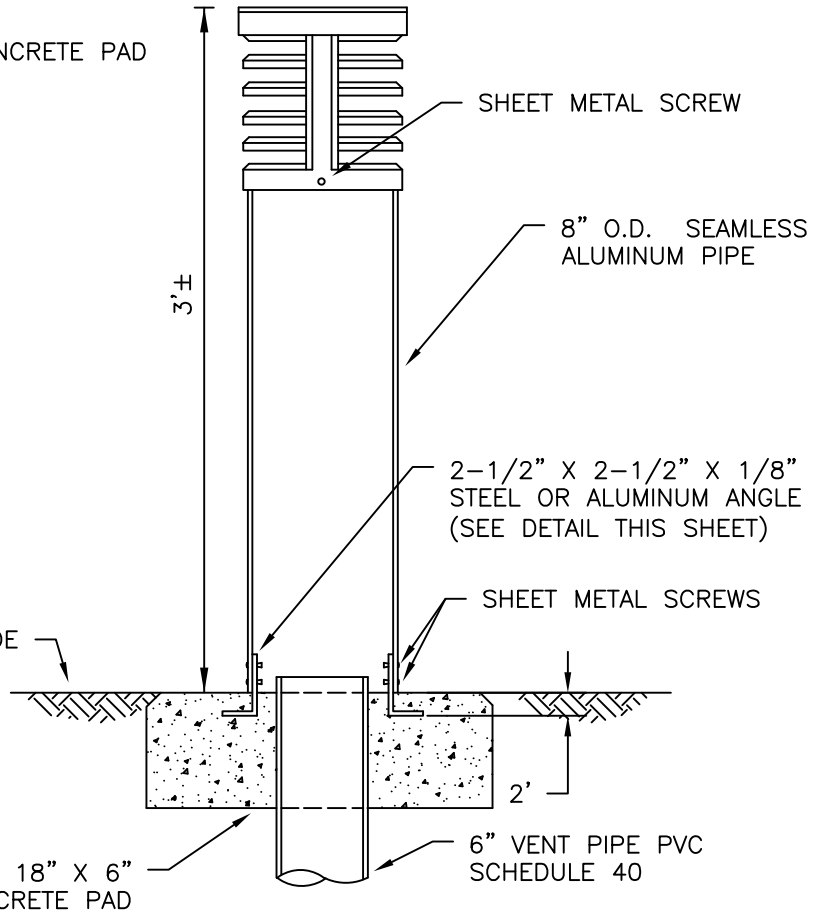

ROUND VENT SCREEN  
N.T.S.

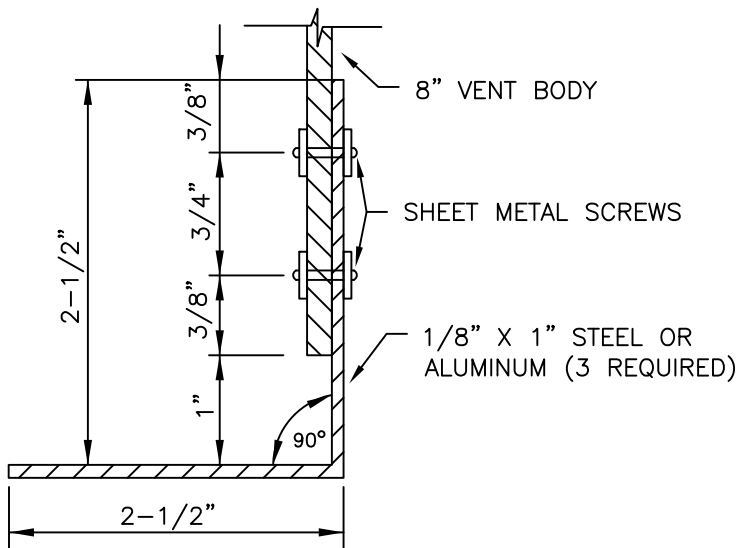

STEEL OR ALUMINUM ANGLE DETAIL  
N.T.S.

**NOTE:**  
COLOR SHALL BE FLAT BLACK UNLESS OTHERWISE SPECIFIED.

FOR USE IN RESIDENTIAL AREAS ONLY AND AS APPROVED BY THE DISTRICT.

## TYPICAL RESIDENTIAL VENT ASSEMBLY



FORT COLLINS - LOVELAND WATER DISTRICT  
Office (970) 226-3104 Fax (970) 226-0186

APPROVED:

DATE:

6-18-2010

SCALE: NTS

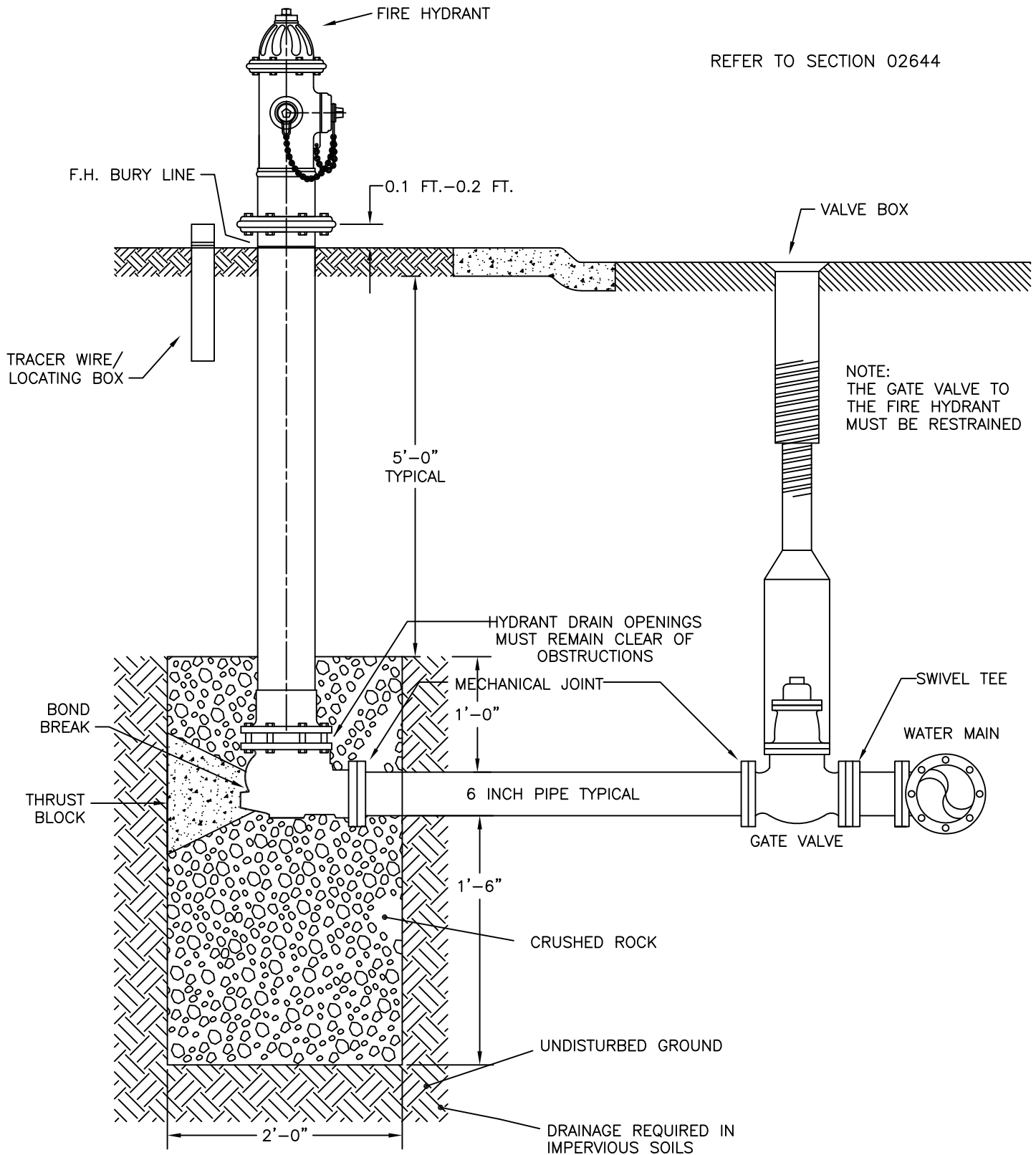

## TYPICAL FIRE HYDRANT INSTALLATION

**FORT COLLINS – LOVELAND WATER DISTRICT**  
 Office (970) 226-3104 Fax (970) 226-0186

APPROVED:

DATE:

6-18-2010

SCALE: NTS



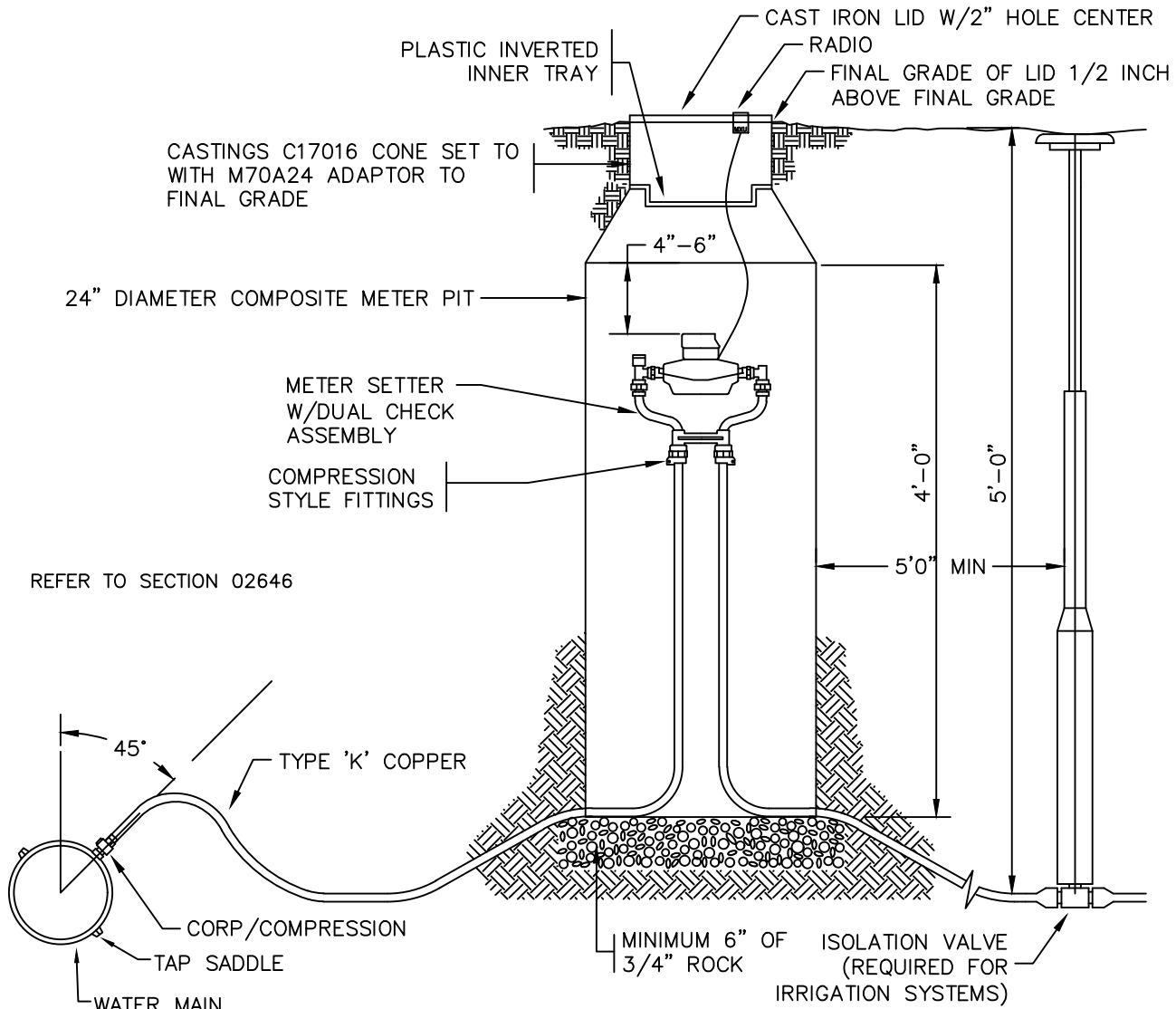

**GENERAL NOTES:**

1. METER PITS ARE TO BE INSTALLED AT CENTER OF LOT UNLESS OTHERWISE APPROVED BY THE DISTRICT. METER PITS SHALL NOT BE LOCATED IN AREAS SUBJECT TO TRAFFIC OF PEDESTRIAN WALKWAYS.
2. NO LANDSCAPING (TREES, SHRUBS, BOULDERS, ETC.) IS TO BE WITHIN 5 FEET OF METER PIT.
3. GROUND SURROUNDING METER PIT SHALL SLOPE AWAY FROM LID.
4. NO PLUMBING CONNECTIONS ARE TO BE MADE IN METER PIT.
5. LAWN SPRINKLER CONNECTIONS ARE TO BE AT LEAST 5 FEET FROM METER PIT ON THE OUTLET SIDE.
6. IRRIGATION SYSTEMS REQUIRE AN ISOLATION VALVE DOWNSTREAM OF THE PIT, MINIMUM OF 5 FEET.
7. VALVES TO BE OPERATED BY DISTRICT PERSONNEL ONLY, WITH EXCEPTION TO THE IRRIGATION ISOLATION VALVES.

## TYPICAL METER PIT INSTALLATION



FORT COLLINS – LOVELAND WATER DISTRICT  
 Office (970) 226-3104 Fax (970) 226-0186

APPROVED:

DATE:

9/25/2017

SCALE: NTS

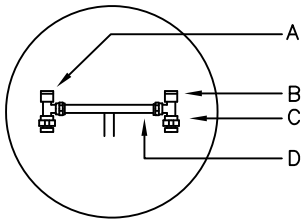

ITEM	NAME	CAT. NO.
A	FORD ANGLE DUAL CHECK VALVE	HHAA34-323-G
B	FORD ANGLE BELL VALVE	BA13-332W
C	FORD "U" BRANCH	U48-43-7.5-G
D	FORD METER IDLERS	IDLER #2

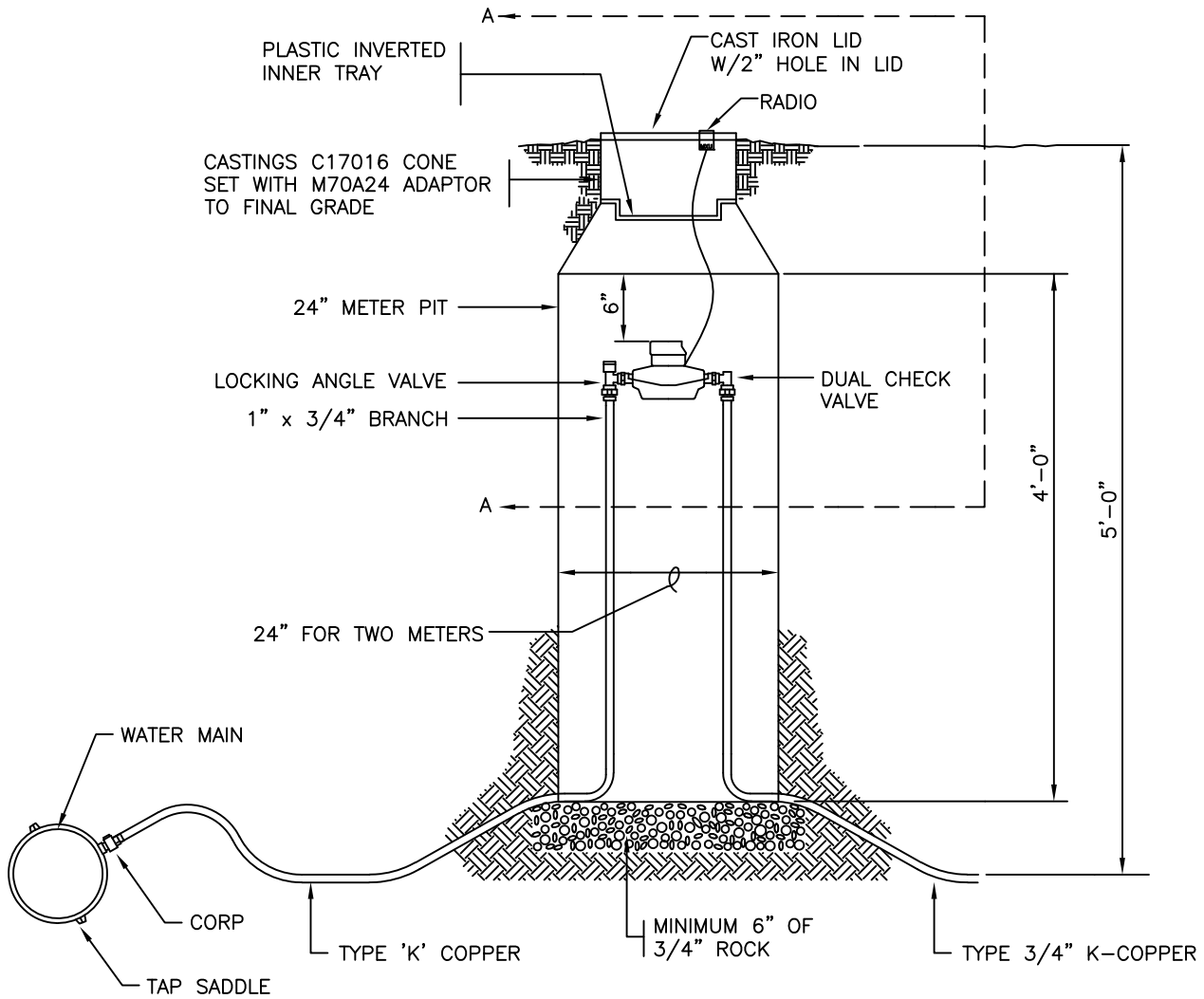
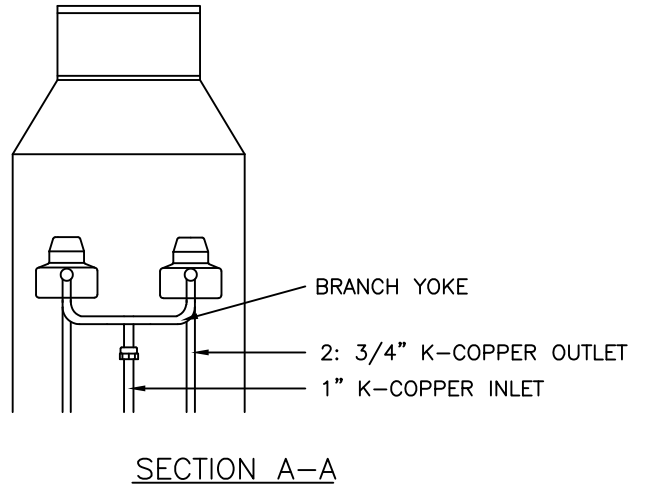

## TYPICAL DOUBLE METER PIT



FORT COLLINS - LOVELAND WATER DISTRICT  
 Office (970) 226-3104 Fax (970) 226-0186

APPROVED:  
 DATE: 9/25/2017

SCALE: NTS

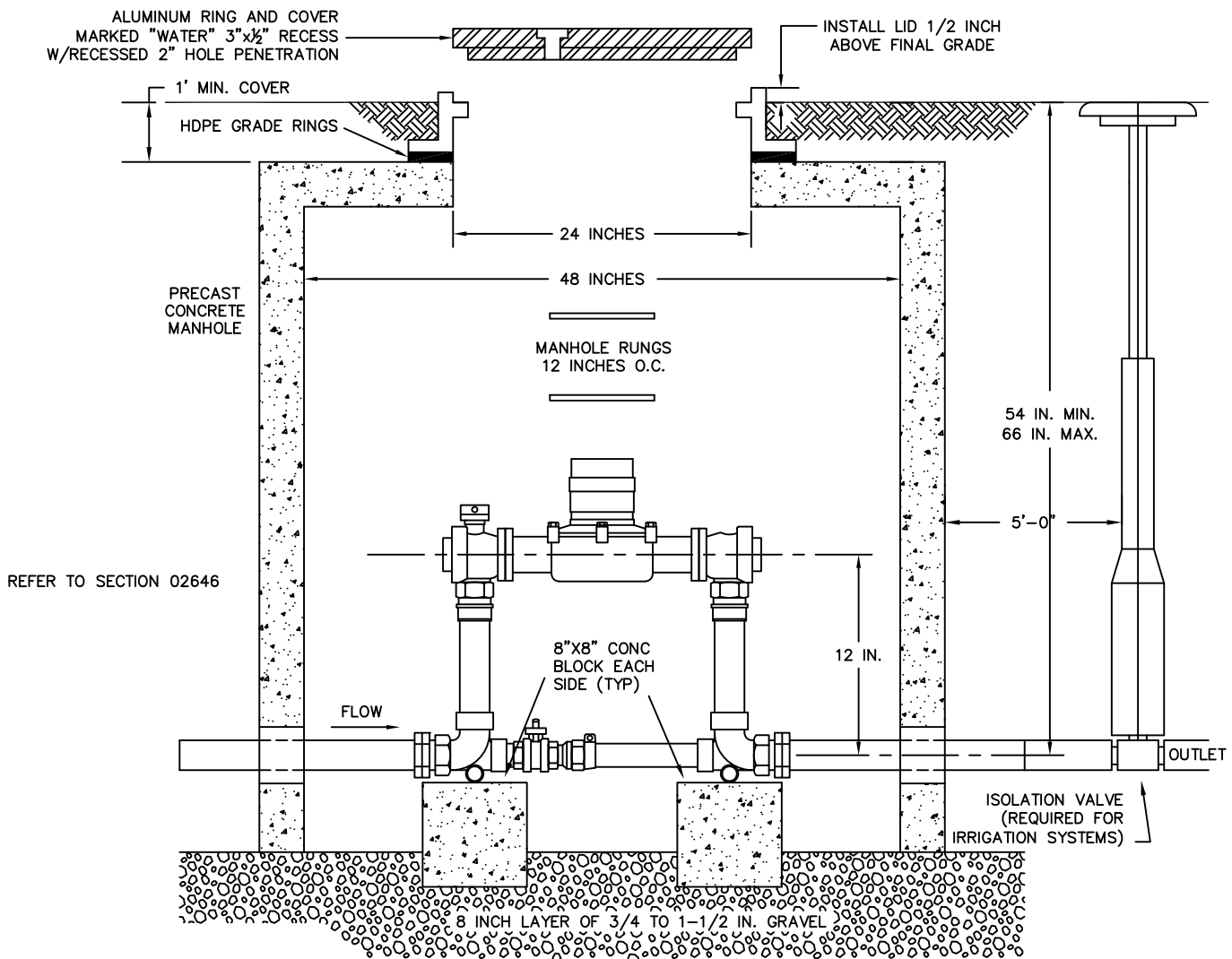

**GENERAL NOTES:**

1. Meter setting devices to be "custom setters" with by-pass and flanged ball valves. Meter setters to be supported by 2 - 18" lengths of 1" iron pipe inserted through eyelets and set atop 8" x 8" concrete blocks.
2. This meter is not to be installed in any street, alley, parking area or driveway.
3. No landscaping (trees, shrubs, boulders, etc.) is to be within 5 feet of meter pit.
4. Ground surrounding meter pit shall slope away from lid.
5. No plumbing connections are to be made in meter pit.
6. Lawn sprinkler connections are to be at least 5 feet from meter pit on the outlet side.
7. Irrigation systems require an isolation valve downstream of vault, minimum of 5 feet.
8. Valves to be operated by District personnel only, with exception to the irrigation isolation valve.

## TYPICAL INSTALLATION FOR 1-1/2" & 2" METERS



**FORT COLLINS - LOVELAND WATER DISTRICT**  
 Office (970) 226-3104 Fax (970) 226-0186

APPROVED:

DATE:

8-6-2014

SCALE: NTS

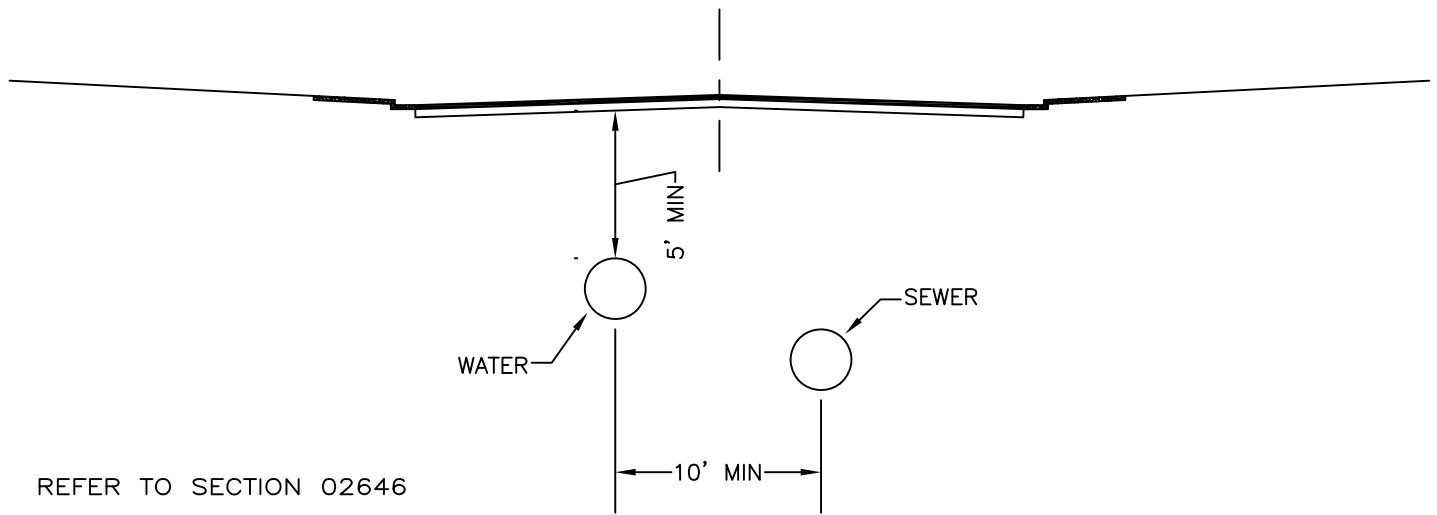
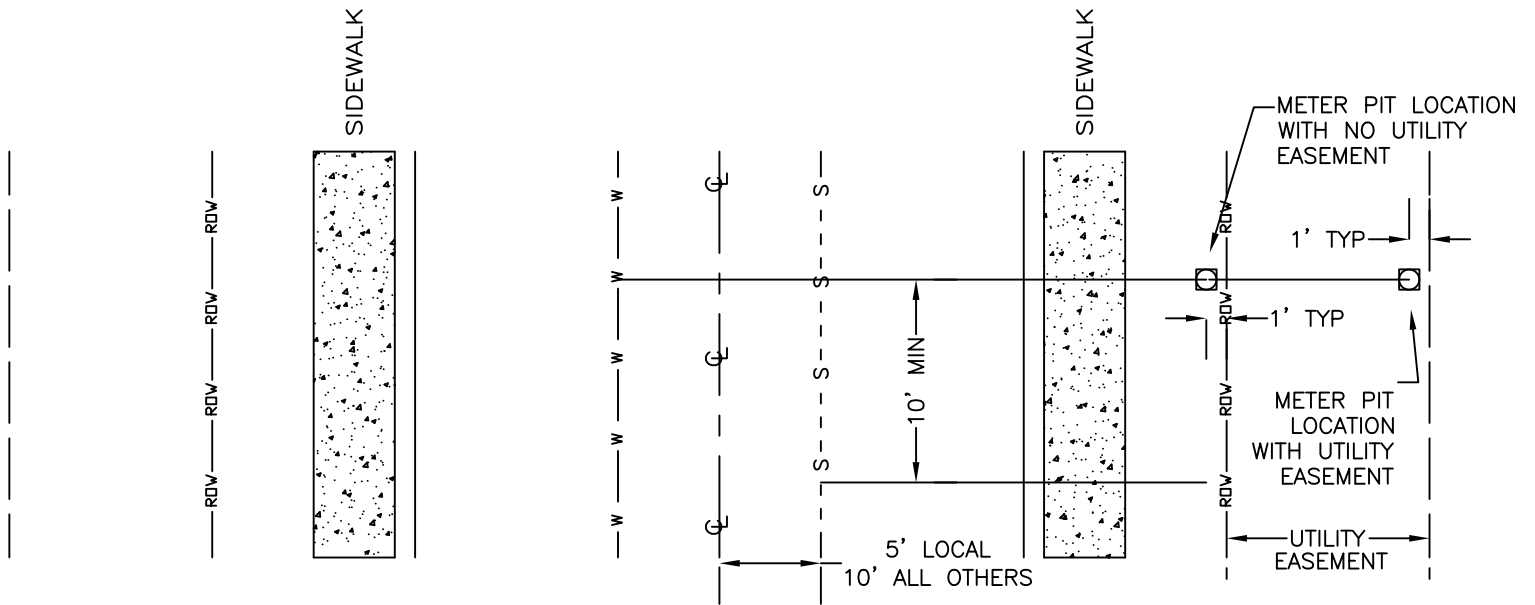

REFER TO SECTION 02646

## TYPICAL UTILILTY SERVICE LOCATION



FORT COLLINS - LOVELAND WATER DISTRICT  
 Office (970) 226-3104 Fax (970) 226-0186

APPROVED:

DATE:

6-18-2010

SCALE: NTS

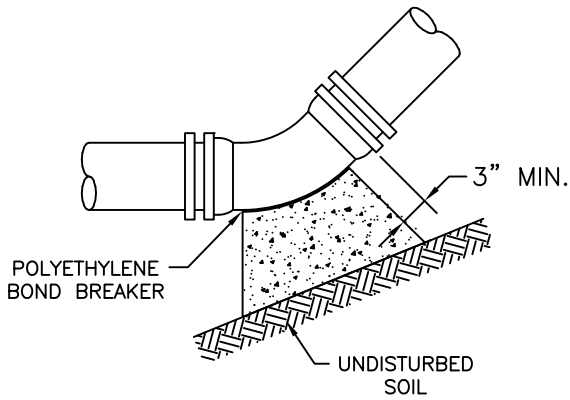

TYPICAL BEND

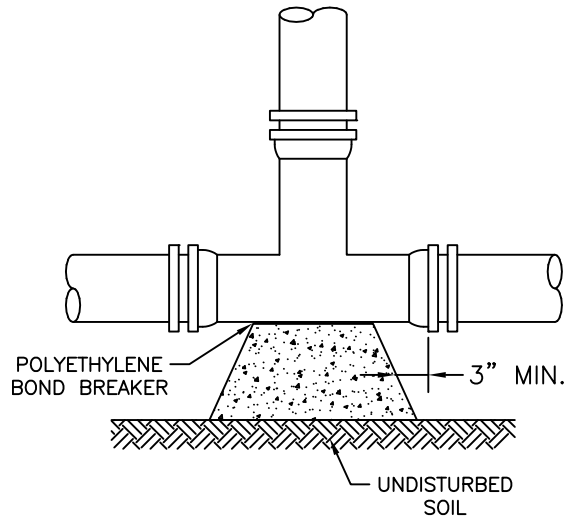

TEE

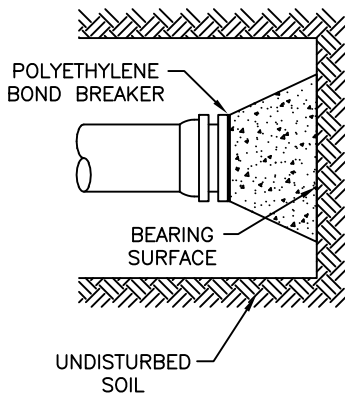

PLUG

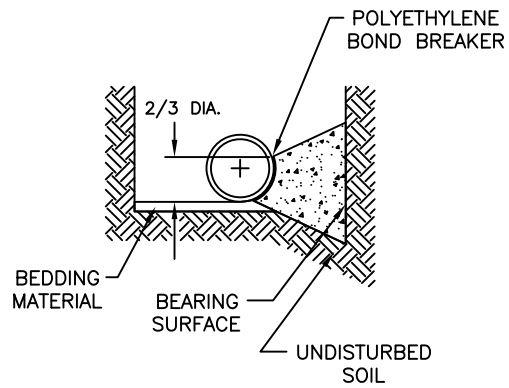

TYPICAL CROSS-SECTION

GENERAL NOTES:

1. Bearing surface areas shown in chart are minimum.
2. All fittings to be wrapped with polyethylene.
3. Data in table is based on a pipeline test pressure of 150 psi (min.) and a soil bearing capacity of 1,000 lb/sq. ft. Adjust the dimensions as required to suit the field conditions encountered by Engineer.
4. Thrust blocks on pipe larger than 12 inches diameter shall be designed for conditions existing at the installation site.
5. Refer to Section 03300 and 02713.

MINIMUM BEARING SURFACE AREA (SQ. FT.)					
PIPE SIZE	BENDS				TEE OR PLUG
	11 1/4"	22 1/4"	45°	90°	
6"	0.7	1.4	2.9	5.3	3.8
8"	1.2	2.5	5.0	9.3	6.5
12"	2.6	5.2	10.2	18.8	13.3

TYPICAL CONCRETE THRUST BLOCKS



FORT COLLINS - LOVELAND WATER DISTRICT  
Office (970) 226-3104 Fax (970) 226-0186

APPROVED:  
DATE: 6-18-2010

SCALE: NTS



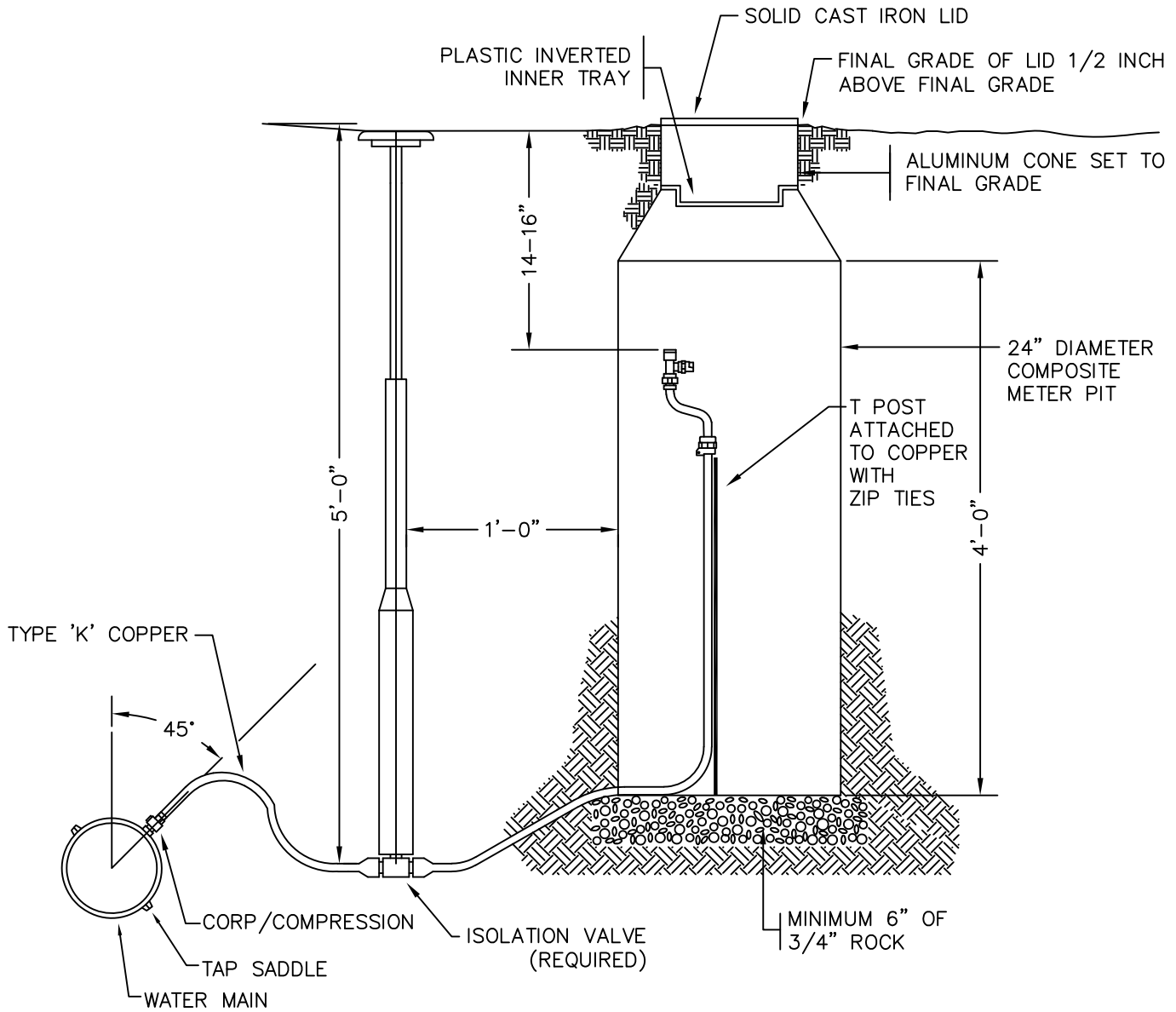

**GENERAL NOTES:**

1. Meter Pits shall not be located in areas subject to traffic or pedestrian walkways.
2. No landscaping (trees, shrubs, boulders, etc.) is to be within 5 feet of meter pit.
3. Ground surrounding meter pit shall slope away from lid.
4. Sample Station locations will be determined by the District.

TYPICAL SAMPLE STATION



FORT COLLINS - LOVELAND WATER DISTRICT  
 Office (970) 226-3104 Fax (970) 226-0186

APPROVED:  
 DATE: 7-9-2014

SCALE: NTS